



## Ball-Bearing Components

### CONTENTS

Ball-Bearing Operating Data & Design Selection .....	2
Ball-Bearing Component Installation Instructions.....	3
Ball-Bearing Assembly Lubrication Recommendation.....	3
Ball-Bearing Clamps & Screws.....	4
Ball-Bearing Boring Procedures & Dimensions for Precision Dies.....	5
Ball-Bearing Retainers.....	6
Ball-Bearing Sleeve Bushings – Pressed Fit.....	7
Ball-Bearing Bushings – Tap Fit .....	8
Ball-Bearing Guide Posts – Pressed Fit .....	9
Ball-Bearing Guide Posts – Tap Fit.....	10
Ball-Bearing Retainers – Metric.....	11
Ball-Bearing Bushings – Sleeve– Metric .....	12
Ball-Bearing Bushings – Tap Fit – Metric.....	13
Ball-Bearing Guide Posts – Straight – Metric .....	14
Ball-Bearing Guide Posts – Tap Fit – Metric.....	15

## Ball-Bearing Operating Data & Design Selection

In component selection, varied characteristics must be taken into consideration when selecting length of guide post, bushing and ball-bearing retainer, such as stroke, shut height and type of operation. To help in your selection, we have supplied engineering data and instructions that should be used as a guide when making your component selection. The following conditions should be considered for the most effective performance in a specific application.

In this condition the guide post, bushing and ball-bearing retainer remain in full contact throughout the stroke cycle. This selection is beneficial and recommended for high speed, high production, short stroke dies.

This may be accomplished by selecting the bushing length that allows the guide post to disengage the bushing at the beginning of the stroke or cycle. This will result in the loss of pre-load while the ball-bearing retainer is still within the bushing.

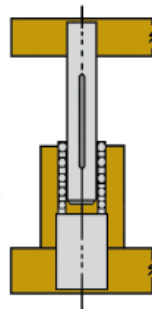

**FULL CONTACT  
PRE-LOAD**

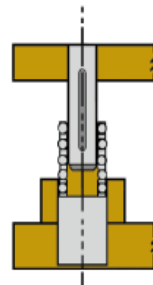

**PRE-LOAD RELIEVED  
AT TOP OF STROKE**

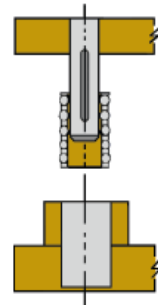

**FULL  
DISENGAGEMENT**

This condition may be utilized with long stroke dies. It also provides safe operation by eliminating pinch points and prevents foreign materials from entering the bushing. A further benefit is it allows for registration of the ball-bearing retainer on each stroke. Removal of the punch holder or die holder from press is possible without total removal of dies.

This condition is permissible when the ball retainer must totally disengage the bushing on applications requiring long strokes. Safety precautions (as outlined on page 16) should always be taken when employing this method.

It should also be noted that the above illustration depicts the proper way to assemble (insert) the guide post and ball-bearing retainer into the bushing.

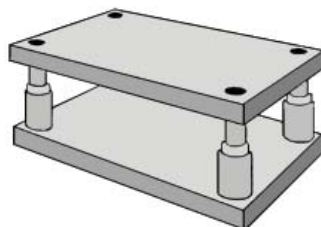

**When in a pre-loaded (rolling press fit) condition, the ball-bearing retainer will travel half the distance of movement. In a die set application it would be half the distance of the press stroke.**

## Ball-Bearing Component Installation Instructions

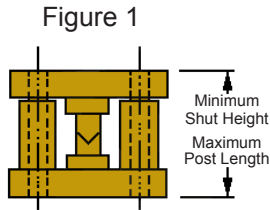

Figure 1  
Punch Holder in contact with Bushing  
Punch and die life depleted

Figure 1 (Minimum Shut Height) determines maximum guide post length and maximum bushing height. This will prevent post bottoming on bolster at minimum shut height if nominal post length is same as minimum shut height.

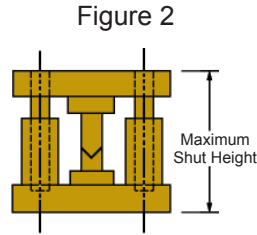
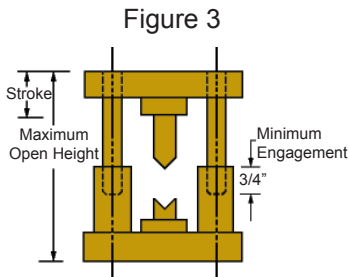

Figure 2  
New Punch and Die

The maximum shut height added to the stroke equals the maximum open height (Figure 3) indicating the minimum engagement for the guide post in the required bushing. It is considered ideal for the minimum engagement to be at least 3/4". If it is less than 3/4", however, the arrangement shown in Figure 4 is recommended.

Keeping in mind that only a small part of the stroke on most dies actually does the work, when conditions shown in Figure 4 are acceptable, together with conditions shown in Figures 1 and 2, there is no need to be concerned with the full length of the stroke and maximum open height.



When required strokes are longer than normal, guide post and retainer, if necessary, may be totally disengaged from bushing on the upward travel, provided (A) operation is vertical, (B) operation is limited to no more than 150 strokes per minute, (C) the ram and gib alignment of the press are accurate.

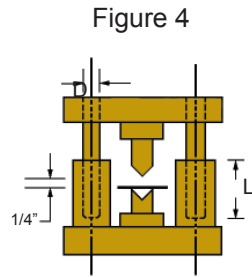

The bushing must always be engaged by the guide post minimum of 3/4" if the operation is included or if speed surpasses 150 strokes per minute. The guide post bushing must engage the retainer during the entire operation, or what is known as full contact pre-load operation.

### GENERAL INFORMATION SPECIFICATIONS

1. The ball-bearing retainer travels half the distance the pin travels or one-half the stroke length.
2. The maximum post length equals(=) minimum shut height minus (-) 1/4" Figure 1. If post length should be greater than minimum shut height it will be necessary to provide clearance for projecting post when press is at bottom of stroke.
3. Maximum straight sleeve length Figure 1 equals (=) minimum shut height minus (-) punch holder thickness minus (-) 1/4". Select nearest standard length.
4. Maximum retainer length equals (=) bushing length minus (-) 1/2".

Post slot lengths available upon request.

## Ball-Bearing Assembly Lubrication Recommendation

In operation of ball assembly, add lubricant once each 8-hour shift by spray or brush application. Use a lightweight spindle oil like Lamina **BALL-LUBE®**. **NEVER USE GREASE.**

**BALL-SCRUBB®** removes heavy soils, dirt or grease from ball-bearing guide pin assemblies.

Just spray it on, wait 3 minutes and spray again. Then blow off excess with compressed air.

Lamina **BALL-SCRUBB®** is an industrial strength cleaner with rust inhibitors, specially formulated to clean debris and grease from all types of ball-bearing assemblies.

**BALL-LUBE®**, when applied after **BALL-SCRUBB®**, locks out wear by chemically bonding to precision surfaces. It provides a tough, long-lasting shield that protects against oxidation and rust.

**BALL-LUBE®** lubricates assemblies and gives them longtime protection against wear, oxidation and heat.

Spray liberally on ball-bearing assemblies.



BALL-LUBE® & BALL-SCRUBB®			
PART NUMBER	DESCRIPTION	PART NUMBER	DESCRIPTION
ARS016	1 Pint BALL-SCRUBB® Spray	ARL016	1 Pint BALL-LUBE® spray
ARS384	1 Case (24) 1 Pint BALL-SCRUBB®	ARL384	1 Case (24) 1 Pint BALL-LUBE®
ARS128	1 Gallon BALL-SCRUBB®	ARL128	1 Gallon BALL-LUBE®
ARS640	5 Gallons BALL-SCRUBB®	ARL640	5 Gallons BALL-LUBE®

BALL-BEARING DEMOUNTABLE COMPONENT CLAMP ARRANGEMENTS				BOLT CIRCLE DIAMETERS	
Nom. Pin Dia.	Standard Left-Right Feed	Front to Back Feed (Center Post die Sets)	Round Dies	DEMOUNTABLE BALL-BEARING BUSHINGS	
				Nom. Bushing Diameter	Bolt Circle Diameter
1, 1¼ & 1½				1	2.438
				1-1/4	2.813
				1-1/2	3.125
				1-3/4	3.438
1¾, 2, 2½ & 3				2	4.000
				2-1/2	4.500
				3	5.000
1¾, 2, 2½ & 3				DEMOUNTABLE BALL-BEARING PINS	
				Nom. Pin Diameter	Bolt Circle Diameter
				1	1.750
				1-1/4	2.000
				1-1/2	2.250
1¾, 2, 2½ & 3				1-3/4	2.625
				2	2.875
				2-1/2	3.375
3	3.875				

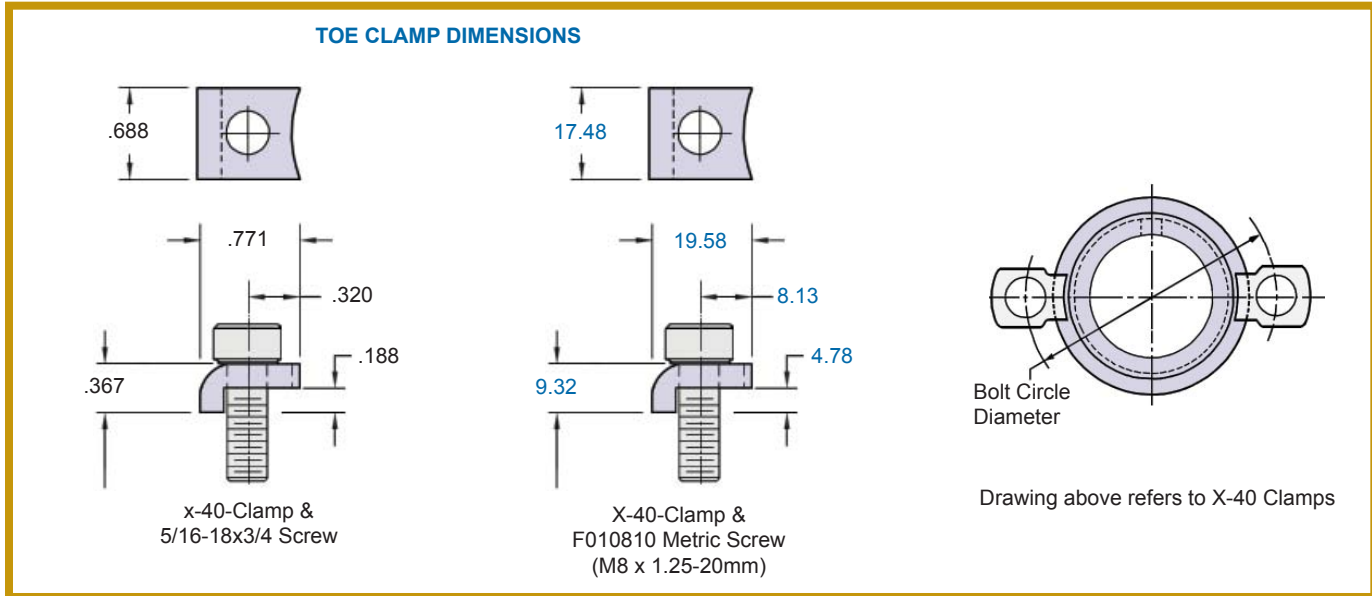

REPLACEMENT KITS CLAMPS & SCREWS – X40-CLAMPS							
PART NUMBER	Nom Pin Diameters	# Clamps & Screws per Kit	No. of Kits Needed	PART NUMBER	Nom Pin Diameters	# Clamps & Screws per Kit	No. of Kits Needed
CSK200002	5/8 - 7/8	2	1	CSK20052	18 - 19	2	1
CSK200003	1 - 1-3/4	3	1	CSK20053	24 - 42	3	1
CSK200002	2 - 2-1/2	2	2	CSK20052	50 - 80	2	2
CSK200003	3 - 4-1/2	3	2				

## Ball-Bearing Boring Procedures & Dimensions for Precision Dies

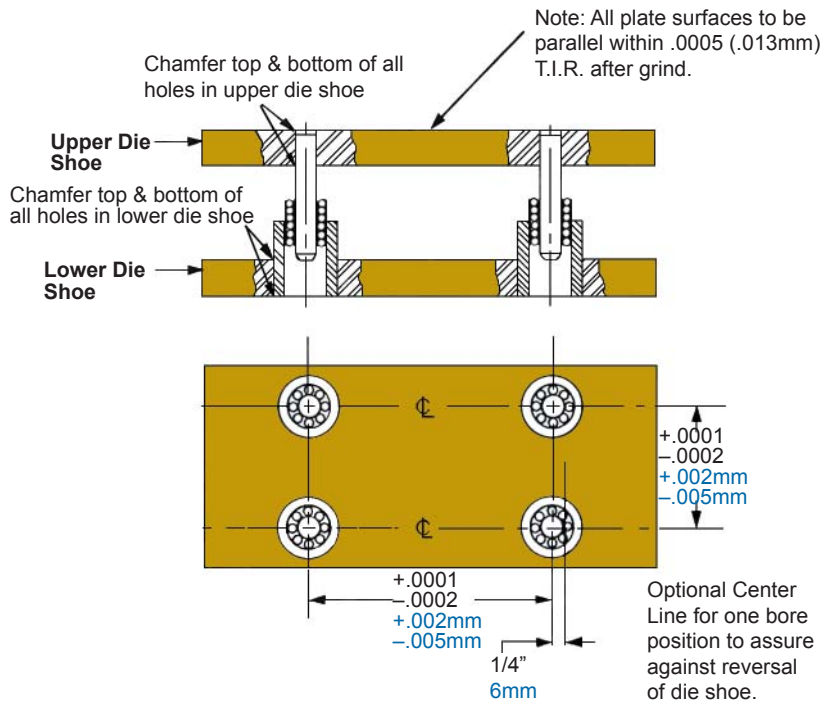

1. Grind die shoe plate parallel within .0005 per foot (.013mm). Then deburr and thoroughly clean plates.

2. Clamp upper and lower shoes together and mount in boring machine.

3. Sweep and strip top surface of plate in boring machine. Shim as required to achieve "0" indicator reading of  $(\begin{smallmatrix} +.0001 & +.002\text{mm} \\ -.0002 & -.005\text{mm} \end{smallmatrix})$  T.I.R. All bores to the square to plate surfaces within  $(\begin{smallmatrix} +.0001 & +.002\text{mm} \\ -.0002 & -.005\text{mm} \end{smallmatrix})$  T.I.R.

4. Step bore in line with hole patterns to dimensions show on chart. All bores to be square to plate surfaces within  $(\begin{smallmatrix} +.0001 & +.002\text{mm} \\ -.0002 & -.005\text{mm} \end{smallmatrix})$  T.I.R.

5. Chamfer both ends of bore.

Complete interchangeability of Lamina ball-bearing guide pins, bushings and retainers makes select fitting unnecessary. No modifications, such as grinding, honing or lapping will be required if mounting and boring instructions which are shown on this page are carefully followed.

**BORE SIZE CHART FOR BALL-BEARING BUSHINGS & PINS**

Nominal Guide Pin Diameter	BORE SIZE for PRESS FIT of Steel Sleeve Bushings AB1 & ABM	BORE SIZE for WRING FIT of Demountable Steel Guide Bushings ABG	BORE SIZE for PRESS FIT of Straight Guide Pins AP1 & APM	BORE SIZE for Tap Fit of Demountable Flanged Guide Pins APG
3/4	<u>1.3872</u> 1.3867	N/A	<u>.7515</u> .7510	N/A
1	<u>1.7172</u> 1.7167	<u>1.7168</u> 1.7163	<u>1.0015</u> 1.0010	<u>1.0016</u> 1.0011
1-1/4	<u>2.1072</u> 2.1067	<u>2.1068</u> 2.1063	<u>1.2510</u> 1.2505	<u>1.2516</u> 1.2511
1-1/2	<u>2.4372</u> 2.4367	<u>2.4368</u> 2.4363	<u>1.5010</u> 1.5005	<u>1.5016</u> 1.5011
1-3/4	<u>2.7472</u> 2.7467	<u>2.7468</u> 2.7463	<u>1.7510</u> 1.7505	<u>1.7516</u> 1.7511
2	<u>3.1622</u> 3.1617	<u>3.1618</u> 3.1613	<u>2.0006</u> 2.0001	<u>2.0016</u> 2.0011
2-1/2	<u>3.6822</u> 3.6817	<u>3.6818</u> 3.6813	<u>2.5006</u> 2.5001	<u>2.5016</u> 2.5011
3	<u>4.1822</u> 4.1817	<u>4.1818</u> 4.1813	<u>3.0006</u> 3.0001	<u>3.0016</u> 3.0011
40mm	<u>64.970</u> 64.940	<u>64.972</u> 64.956	<u>39.975</u> 39.950	<u>39.964</u> 39.952
50mm	<u>80.962</u> 80.927	<u>80.971</u> 80.959	<u>49.975</u> 49.950	<u>49.964</u> 49.952
63mm	<u>94.962</u> 94.927	<u>94.972</u> 94.960	<u>62.970</u> 62.940	<u>62.964</u> 62.952
80mm	<u>111.959</u> 111.924	<u>111.972</u> 111.960	<u>79.968</u> 79.938	<u>79.964</u> 79.952

## Ball-Bearing – Retainers

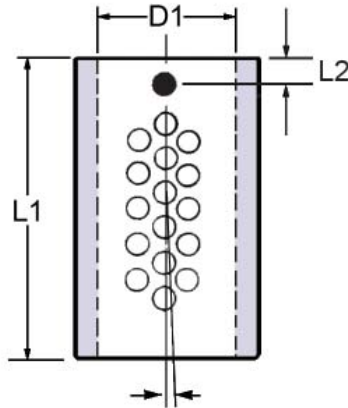

Radial placement reduces wear and tracking

Lamina ball-bearing retainers (AR1) are made of a heat-treated aluminum alloy that combines lightness and strength.

Each retainer is quality inspected for dimensional tolerance and all burrs are removed prior to ball insertion.

Ball bearings are of the highest quality AAA1 Grade (25 millionth class), continually inspected to meet our exacting tolerance.

After the ball bearings have been inserted into the retainer, they are then staked using Lamina's unique method that allows free movement with maximum security.

After staking, the retainers are then scrubbed to remove all metal particles that could cause accelerated tracking and grooving in the post and bushing.

Ball bearings are placed in retainers in an off-line radial pattern that offers optimum life in high or low speed presses.

Ball-bearing retainers are fastened to the guide post by means of a set screw and slot in guide post and are interchangeable with other manufacturers using this method.

BALL-BEARING RETAINER			
(STANDARD)			
PART NUMBER	D1	L1	L2 SET SCREW
AR1-0606	3/4"	1.50	.250
AR1-0607		1.75	
AR1-0608		2.00	
AR1-0609		2.25	
AR1-0610		2.50	
AR1-0806	1"	1.50	
AR1-0807		1.75	
AR1-0808		2.00	
AR1-0809		2.25	
AR1-0810		2.50	
AR1-1008	1-1/4"	2.00	
AR1-1009		2.25	
AR1-1010		2.50	
AR1-1011		2.75	
AR1-1012		3.00	
AR1-1013	1-1/2"	3.25	
AR1-1210		2.50	
A41-1211		2.75	
AR1-1212		3.00	
AR1-1213		3.25	
AR1-1214	1-3/4"	3.50	
AR1-1215		3.75	
AR1-1411		2.75	
AR1-1412		3.00	
AR1-1413		3.25	
AR1-1414	2"	3.50	
AR1-1415		3.75	
AR1-1416		4.00	
AR1-1417		4.25	
AR1-1613		2-1/2"	4.50
AR1-1614	5.00		
AR1-1615	5.50		
AR1-1616	6.00		
AR1-1617	6.25		
AR1-1618	3"	6.50	
AR1-1622		7.00	
AR1-2018		7.50	
AR1-2020		8.00	
AR1-2022		8.50	
AR1-2024	3.13	9.00	
AR1-2025		9.50	
AR1-2026		10.00	
AR1-2028		10.50	
AR1-2420		11.00	
AR1-2424	3.13	11.50	
AR1-2428		12.00	

Part numbers highlighted in blue designate that the retainer length is recommended for general die set applications. Lengths not highlighted are for limited space use and special applications.

## Ball-Bearing Sleeve Bushings – Pressed Fit

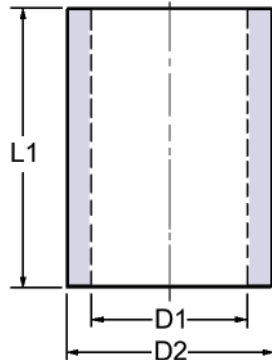

Lamina's Ball-Bearing Guide Assembly Bushings (AB1) are made from vacuum degassed chrome alloy steel, hardened to precise Rockwell limits to give minimum tracking, grooving and downtime.

Lamina's ball-bearing bushings are ground and honed to exacting tolerance limits. Using electronic and air checking instruments on the I.D. and O.D. make them interchangeable and do not require select fitting.

The top is chamfered on the I.D. to minimize wear and aid alignment when disengagement is required.

To minimize bushing close-in which is a result of press fit and to eliminate any additional grinding or honing, boring instructions are provided in this catalog.

BALL-BEARING BUSHINGS – STRAIGHT SLEEVE															
PART NUMBER	NOM PIN DIA	D1	D2	L1	PART NUMBER	NOM PIN DIA	D1	D2	L1	PART NUMBER	NOM PIN DIA	D1	D2	L1	
AB1-0607	3/4"	1.1269 1.1266	1.3872 1.3867	1.625	AB1-1214	1-1/2"	1.8766 1.8763	2.4372 2.4367	3.375	AB1-1619	2"	2.5016 2.5013	3.1622 3.1617	4.625	
AB1-0608				1.875	AB1-1215				3.625	AB1-1620				4.875	
AB1-0609				2.125	AB1-1216				3.875	AB1-1621				5.125	
AB1-0610				2.375	AB1-1217				4.125	AB1-1622				5.375	
AB1-0611				2.625	AB1-1218				4.375	AB1-1624				5.875	
AB1-0612				2.875	AB1-1219				4.625	AB1-1626				6.375	
AB1-0613				3.125	AB1-1220				4.875	AB1-1628				6.875	
AB1-0614				3.375	AB1-1221				5.125	AB1-1630				7.375	
AB1-0615				3.625	AB1-1222				5.375	AB1-1632				7.875	
AB1-0616				3.875	AB1-1224				5.875	AB1-1634				8.375	
AB1-0618				4.375	AB1-1226				6.375	AB1-1636				8.875	
AB1-0624				5.875	AB1-1230				7.375	AB1-1640				9.875	
AB1-0808				1.875	AB1-1232				7.875	AB1-1642				10.375	
AB1-0809				2.125	AB1-1234				8.375	AB1-1644				10.875	
AB1-0810				2.375	AB1-1236				8.875	AB1-1648				11.875	
AB1-0811				2.625	AB1-1240				9.875	AB1-1652				12.875	
AB1-0812	2.875	AB1-1242	10.375	AB1-1656	13.875										
AB1-0813	3.125	AB1-1244	10.875	AB1-2022	5.375										
AB1-0814	3.375	AB1-1248	11.875	AB1-2024	5.875										
AB1-0815	3.625	AB1-1412	2.875	AB1-2026	6.375										
AB1-0816	3.875	AB1-1414	3.375	AB1-2028	6.875										
AB1-0817	4.125	AB1-1415	3.625	AB1-2030	7.375										
AB1-0818	4.375	AB1-1416	3.875	AB1-2032	7.875										
AB1-0819	4.625	AB1-1417	4.125	AB1-2034	8.375										
AB1-0820	4.875	AB1-1418	4.375	AB1-2036	8.875										
AB1-0822	5.375	AB1-1419	4.625	AB1-2038	9.375										
AB1-0824	5.875	AB1-1420	4.875	AB1-2040	9.875										
AB1-0826	6.375	AB1-1421	5.125	AB1-2042	10.375										
AB1-0828	6.875	AB1-1422	5.375	AB1-2044	10.875										
AB1-1010	1-1/4"	1.6266 1.6263	2.1072 2.1067	2.375	AB1-1424	1-3/4"	2.1266 2.1263	2.7472 2.7467	5.875	AB1-2048	2-1/2"	3.0016 3.0013	3.6822 3.6817	11.875	
AB1-1011				2.625	AB1-1426				6.375	AB1-2052				12.875	
AB1-1012				2.875	AB1-1428				6.875	AB1-2056				13.875	
AB1-1013				3.125	AB1-1430				7.375	AB1-2424				5.875	
AB1-1014				3.375	AB1-1432				7.875	AB1-2426				6.375	
AB1-1015				3.625	AB1-1434				8.375	AB1-2428				6.875	
AB1-1016				3.875	AB1-1436				8.875	AB1-2430				7.375	
AB1-1017				4.125	AB1-1438				9.375	AB1-2432				7.875	
AB1-1018				4.375	AB1-1440				9.875	AB1-2434				8.375	
AB1-1019				4.625	AB1-1442				10.375	AB1-2436				8.875	
AB1-1020				4.875	AB1-1444				10.875	AB1-2438				9.375	
AB1-1022				5.375	AB1-1448				11.875	AB1-2440				9.875	
AB1-1024				5.875	AB1-1452				12.875	AB1-2442				10.375	
AB1-1026				6.375	AB1-1612				2.875	AB1-2444				10.875	
AB1-1028				6.875	AB1-1614				3.375	AB1-2448				11.875	
AB1-1032				7.875	AB1-1615				3.625	AB1-2452				12.875	
AB1-1036	8.875	AB1-1616	3.875	AB1-2456	13.875										
AB1-1212	1-1/2"	1.8766 1.8763	2.4372 2.4367	2.875	AB1-1617	2"	2.5016 2.5013	3.1622 3.1617	4.125	See page 5 for bore size information.					
AB1-1213				3.125	AB1-1618				4.375						

## Ball-Bearing – Bushings – Tap Fit

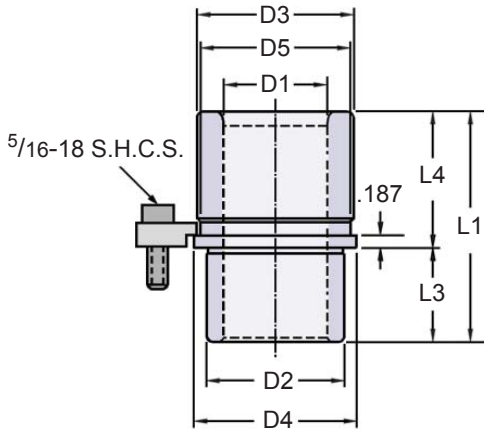

Demountable shoulder bushings offer all the advantages of straight sleeve bushings and combine them with the convenience of easy assembly and disassembly.

These clamp type bushings are meant to be wring fit into the die shoe and should never be forced or inserted by hammering.

X-40-Clamps and socket head screws are provided to hold the bushings in place.

**Clamping information is on page 4.**  
**See page 5 for bore size information.**

Unground demountable bushings are available by special order only.

BALL-BEARING BUSHINGS – DEMOUNTABLE									
PART NUMBER	NOM PIN DIA	D1	D2	D3	D4	D5	L1	L3	L4
ABG0808	1"	1.3769 1.3766	1.7163 1.7160	1.920	1.995	1.775	1.875	1.000	0.875
ABG0809							2.125		1.125
ABG0811							2.625		1.625
ABG0812							2.875		1.875
ABG0813							3.125		2.125
ABG0814							3.375		2.375
ABG0815	3.625	2.625							
ABG1010	1-1/4"	1.6266 1.6263	2.1063 2.1060	2.280	2.355	2.125	2.375	1.000	1.375
ABG1011							2.625		1.625
ABG1012							2.875		1.875
ABG1013							3.125		2.125
ABG1014							3.375		2.375
ABG1015							3.625		2.625
ABG1016							3.875		2.875
ABG1017							4.125		3.125
ABG1018							4.375		3.375
ABG1020							4.875		3.875
ABG1022	5.375	4.375							
ABG1024	5.875	4.875							
ABG1212	1-1/2"	1.8766 1.8763	2.4363 2.4360	2.600	2.675	2.425	2.875	1.250	1.625
ABG1213							3.125		1.875
ABG1214							3.375		2.125
ABG1215							3.625		2.375
ABG1216							3.875		2.625
ABG1217							4.125		2.875
ABG1218							4.375		3.125
ABG1219							4.625		3.375
ABG1220							4.875		3.625
ABG1222							5.375		4.125
ABG1224	5.875	4.625							
ABG1412	1-3/4"	2.1266 2.1263	2.7463 2.7460	2.920	2.995	2.755	2.875	1.250	1.625
ABG1414							3.375		2.125
ABG1416							3.875		2.625
ABG1417							4.125		2.875
ABG1418							4.375		3.125
ABG1419							4.625		3.375
ABG1420							4.875		3.625
ABG1421							5.125		3.875
ABG1422							5.375		4.125
ABG1424							5.875		4.625
ABG1426	6.375	5.125							
ABG1428	6.875	5.625							
ABG1430	7.375	6.125							
ABG1612	2"	2.5016 2.5013	3.1613 3.1610	3.500	3.565	3.295	2.875	1.250	1.625
ABG1614							3.375		2.125
ABG1615							3.625		2.375
ABG1616							3.875		2.625
ABG1617							4.125		2.875
ABG1618							4.375		3.125
ABG1619							4.625		3.375
ABG1620							4.875		3.625
ABG1621							5.125		3.875
ABG1622							5.375		4.125
ABG1624	5.875	4.625							
ABG1626	6.375	5.125							
ABG1628	6.875	5.625							
ABG1630	7.375	6.125							
ABG2020	2-1/2"	3.0016 3.0013	3.6813 3.6810	4.000	4.075	3.765	4.875	1.250	3.625
ABG2022							5.375		4.125
ABG2024							5.875		4.625
ABG2026							6.375		5.125
ABG2028							6.875		5.625
ABG2030	7.375	6.125							
ABG2420	3"	3.5016 3.5013	4.1813 4.1810	4.500	4.575	4.275	4.875	1.250	3.625
ABG2422							5.375		4.125
ABG2424							5.875		4.625
ABG2426							6.375		5.125
ABG2428							6.875		5.625
ABG2430	7.375	6.125							

## Ball-Bearing Guide Posts – Pressed Fit

Lamina's Precision Guide Post (AP1) for ball-bearing assemblies are made from chrome alloy steel, hardened to provide maximum protection against tracking and accelerated wear.

Ground to a high degree of tolerance accuracy that also provides a smooth hard wearing surface to assure free rolling of balls to maintain constant, predictable preload and complete interchangeability, not only with our own but other manufacturers' also.

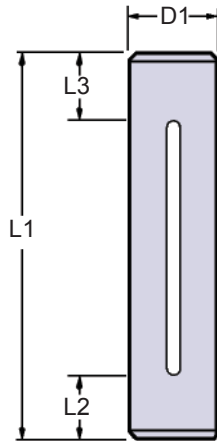

BALL-BEARING GUIDE POSTS – STRAIGHT											
PART NUMBER	NOM PIN DIA	D1	L1	L2	L3	PART NUMBER	NOM PIN DIA	D1	L1	L2	L3
AP1-0612	3/4"	.7530 .7527	2.875	0.625	0.813	AP1-1422	1-3/4"	1.7530 1.7525	5.375	1.313	1.313
AP1-0613			3.125	0.625	0.813	AP1-1423			5.625	1.500	1.500
AP1-0614			3.375	0.625	0.813	AP1-1424			5.875	1.500	1.500
AP1-0615			3.625	0.625	0.813	AP1-1425			6.125	1.500	1.500
AP1-0616			3.875	0.625	0.813	AP1-1426			6.375	1.625	1.750
AP1-0617			4.125	0.625	0.813	AP1-1428			6.875	1.625	1.750
AP1-0618			4.375	0.625	0.813	AP1-1430			7.375	1.625	1.750
AP1-0619			4.625	0.875	1.000	AP1-1432			7.875	1.625	1.750
AP1-0620			4.875	0.875	1.000	AP1-1434			8.375	1.625	1.750
AP1-0622			5.375	0.875	1.000	AP1-1436			8.875	1.625	2.250
AP1-0624	5.875	0.875	1.000	AP1-1438	9.375	1.625	2.250				
AP1-0815	1"	1.0030 1.0027	3.625	0.875	1.000	AP1-1440	2"	2.0031 2.0026	9.875	1.625	2.250
AP1-0816			3.875	0.875	1.000	AP1-1442			10.375	1.625	2.250
AP1-0817			4.125	0.875	1.000	AP1-1444			10.875	1.625	2.250
AP1-0818			4.375	0.875	1.000	AP1-1446			11.375	1.625	2.250
AP1-0819			4.625	0.875	1.250	AP1-1448			11.875	1.625	2.250
AP1-0820			4.875	0.875	1.250	AP1-1450			12.375	1.625	2.875
AP1-0821			5.125	0.875	1.250	AP1-1452			12.875	1.625	2.875
AP1-0822			5.375	0.875	1.250	AP1-1456			13.875	1.625	2.875
AP1-0823			5.625	0.875	1.250	AP1-1460			14.875	1.625	2.875
AP1-0824			5.875	0.875	1.250	AP1-1468			16.875	1.625	2.875
AP1-0826	6.375	0.875	1.500	AP1-1622	2-1/2"	2.5031 2.5026	5.375	1.375	1.500		
AP1-0828	6.875	0.875	1.500	AP1-1623			5.625	1.375	1.500		
AP1-0830	7.375	0.875	1.500	AP1-1624			5.875	1.375	1.500		
AP1-0832	7.875	0.875	1.500	AP1-1625			6.125	1.375	1.500		
AP1-0834	8.375	0.875	2.000	AP1-1626			6.375	1.750	1.875		
AP1-0836	8.875	0.875	2.000	AP1-1627			6.625	1.750	1.875		
AP1-1018	4.375	1.000	1.375	AP1-1628			6.875	1.750	1.875		
AP1-1019	4.625	1.000	1.375	AP1-1629			7.125	1.750	1.875		
AP1-1020	4.875	1.000	1.375	AP1-1630			7.375	1.750	1.875		
AP1-1021	5.125	1.000	1.375	AP1-1631			7.625	1.750	1.875		
AP1-1022	5.375	1.000	1.375	AP1-1632	7.875	1.750	1.875				
AP1-1023	5.625	1.000	1.375	AP1-1634	8.375	1.875	2.250				
AP1-1024	5.875	1.000	1.375	AP1-1636	8.875	1.875	2.250				
AP1-1026	6.375	1.125	1.750	AP1-1638	9.375	1.875	2.250				
AP1-1028	6.875	1.125	1.750	AP1-1640	9.875	1.875	2.250				
AP1-1030	7.375	1.125	1.750	AP1-1642	10.375	1.875	2.250				
AP1-1032	7.875	1.125	1.750	AP1-1644	10.875	1.875	2.250				
AP1-1034	8.375	1.125	1.750	AP1-1646	11.375	1.875	3.000				
AP1-1036	8.875	1.125	1.750	AP1-1648	11.875	1.875	3.000				
AP1-1040	9.875	1.125	2.250	AP1-1650	12.375	1.875	3.000				
AP1-1044	10.875	1.125	2.250	AP1-1652	12.875	1.875	3.000				
AP1-1048	11.875	1.875	2.250	AP1-1656	13.875	2.375	3.000				
AP1-1218	1-1/2"	1.5030 1.5026	4.375	1.375	1.313	AP1-1660	3"	3.0031 3.0025	14.875	1.875	3.000
AP1-1219			4.625	1.375	1.313	AP1-1664			15.875	1.875	3.000
AP1-1220			4.875	1.375	1.313	AP1-1668			16.875	1.875	3.000
AP1-1221			5.125	1.375	1.313	AP1-1672			17.875	1.875	3.000
AP1-1222			5.375	1.375	1.313	AP1-2032			7.875	1.625	2.500
AP1-1223			5.625	1.250	1.563	AP1-2034			8.375	1.625	2.500
AP1-1224			5.875	1.250	1.563	AP1-2036			8.875	2.375	2.750
AP1-1226			6.375	1.250	1.563	AP1-2040			9.875	2.375	3.000
AP1-1228			6.875	1.375	2.000	AP1-2044			10.875	2.375	3.000
AP1-1230			7.375	1.375	2.000	AP1-2048			11.875	2.375	3.000
AP1-1232	7.875	1.375	2.000	AP1-2052	12.875	2.375	3.000				
AP1-1234	8.375	1.375	2.000	AP1-2056	13.875	2.375	3.000				
AP1-1236	8.875	1.625	2.500	AP1-2068	16.875	2.625	4.000				
AP1-1238	9.375	1.625	2.500	AP1-2080	19.875	2.625	4.000				
AP1-1240	9.875	1.625	2.500	AP1-2432	7.875	2.000	2.375				
AP1-1242	10.375	1.625	2.500	AP1-2434	8.375	1.875	2.500				
AP1-1244	10.875	1.625	2.500	AP1-2436	8.875	1.875	2.500				
AP1-1246	11.375	1.625	2.500	AP1-2440	9.875	2.875	3.000				
AP1-1248	11.875	1.625	2.500	AP1-2444	10.875	2.875	3.000				
AP1-1250	12.375	1.625	2.500	AP1-2448	11.875	2.875	3.000				
AP1-1252	12.875	1.625	2.500	AP1-2452	12.875	2.875	3.000				
AP1-1256	13.875	1.625	2.500	AP1-2456	13.875	2.875	3.000				
AP1-1420	1-3/4"	1.7530 1.7525	4.875	1.313	1.313	AP1-2468	3"	3.0031 3.0025	16.875	2.875	4.000
AP1-1421			5.125	1.313	1.313	AP1-2480			19.875	2.875	4.000

## Ball-Bearing Guide Posts – Tap Fit

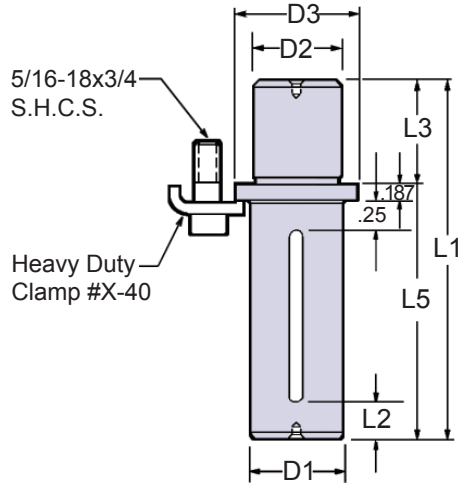

Designed to expedite die repair, these Ball-Bearing flanged guide posts offer:

- Large savings in maintenance, repair costs and downtime
- Wide variety of sizes
- Long, trouble-free production runs
- Highest quality workmanship and materials
- “D2” dimension is finished ground

Clamps & Screws included

Pins with unground D2 dimensions are available as specials.

### BALL-BEARING GUIDE POSTS – DEMOUNTABLE

PART NUMBER	NOM PIN DIA	D1	D2	D3	L1	L2	L3	L5	PART NUMBER	NOM PIN DIA	D1	D2	D3	L1	L2	L3	L5
APG0815	1"	1.0030 1.0027	1.0011 1.0006	1.312	3.625	0.875	1.188	2.437	APG1626	2"	2.0031 2.0026	2.0011 2.0006	2.500	6.375	1.375	1.938	4.437
APG0819					4.625			3.437	APG1627					6.625	1.375		4.687
APG0820					4.875			3.687	APG1628					6.875	1.625		4.937
APG0821					5.125			3.937	APG1629					7.125	1.625		5.187
APG0824					5.875			4.687	APG1630					7.375	1.625		5.437
APG0826					6.375			5.187	APG1632					7.875	1.625		5.937
APG0828					6.875			5.687	APG1634					8.375	1.625		6.437
APG0830					7.375			6.187	APG1636					8.875	1.625		6.937
APG0836					8.875			7.687	APG1638					9.375	1.875		7.437
APG1021	1-1/4"	1.2530 1.2526	1.2511 1.2506	1.562	5.125	0.875	1.188	3.937	APG1640	2-1/2"	2.5031 2.5026	2.5011 2.5006	3.000	9.875	1.875	1.938	7.937
APG1022					5.375	0.875		4.187	APG1642					10.375	1.875		8.437
APG1023					5.625	0.875		4.437	APG1644					10.875	1.875		8.937
APG1026					6.375	0.875		5.187	APG1648					11.875	1.875		9.937
APG1028					6.875	0.875		5.687	APG1650					11.375	1.875		10.437
APG1030					7.375	0.875		6.187	APG1652					12.875	1.875		10.937
APG1032					7.875	1.125		6.687	APG1656					13.875	1.875		11.937
APG1034					8.375	1.125		7.187	APG1660					14.875	1.875		12.937
APG1036					8.875	1.125		7.687	APG1664					15.875	1.875		13.937
APG1218	1-1/2"	1.5030 1.5026	1.5011 1.5006	1.875	4.375	1.125	1.438	2.937	APG1668	2-1/2"	2.5031 2.5026	2.5011 2.5006	3.000	16.875	1.875	1.938	14.937
APG1222					5.375	1.125		3.937	APG1672					17.875	1.875		15.937
APG1223					5.625	1.125		4.187	APG2032					7.875	2.375		5.937
APG1224					5.875	1.125		4.437	APG2034					8.375	2.375		6.437
APG1226					6.375	1.125		4.937	APG2036					8.875	2.375		6.937
APG1228					6.875	1.375		5.437	APG2040					9.875	2.375		7.937
APG1230					7.375	1.375		5.937	APG2044					10.875	2.375		8.937
APG1234					8.375	1.375		6.937	APG2048					11.875	2.375		9.937
APG1236					8.875	1.375		7.437	APG2052					12.875	2.375		10.937
APG1238	9.375	1.375	7.937	APG2056	13.875	2.375	11.937										
APG1242	10.375	1.375	8.937	APG2068	16.875	2.375	14.937										
APG1424	1-3/4"	1.7530 1.7525	1.7511 1.7506	2.250	5.875	1.375	1.688	4.187	APG2080	3"	3.0031 3.0025	3.0011 3.0006	3.500	19.875	2.375	2.438	17.937
APG1428					6.875	1.375		5.187	APG2432					7.875	1.875		5.437
APG1430					7.375	1.375		5.687	APG2434					8.375	1.875		5.937
APG1432					7.875	1.375		6.187	APG2436					8.875	1.875		6.437
APG1434					8.375	1.375		6.687	APG2440					9.875	2.375		7.437
APG1436					8.875	1.625		7.187	APG2444					10.875	2.375		8.437
APG1438					9.375	1.625		7.687	APG2448					11.875	2.375		9.437
APG1440					9.875	1.625		8.187	APG2452					12.875	2.875		10.437
APG1442					10.375	1.625		8.687	APG2456					13.875	2.875		11.437
APG1448	11.875	1.625	10.187	APG2468	16.875	2.875	14.437										
See page 4 for toe clamp placement instructions.									APG2480				19.875	2.875		17.437	

## Lamina offers a generous range of Metric Ball-Bearing Components to suit your needs.

- Retainers
- Sleeve Bushings
- Tap-Fit Bushings (Demountable)
- Straight Pins
- Tap-Fit Pins (Demountable)

*Specials are available.*

### Ball-Bearing Retainers – Metric

- Heat-Treated Aluminum
- AAA1 Grade Ball Bearings
- Off-line radial pattern
- Set-screw and slot fastening

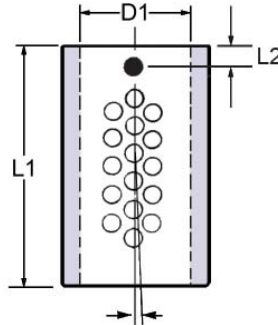

BALL-BEARING RETAINERS – METRIC			
PART NUMBER	D1 Nom Pin Dia	L1 Length	L2 SET SCREW
ARM032058	32	58	6.35
ARM032070		70	
ARM032083		83	
ARM040065	40	65	6.35
ARM040077		77	
ARM040096		96	
ARM050083	50	83	6.35
ARM050102		102	
ARM050114		114	
ARM063178	63	178	7.94
ARM080178	80	178	7.94

Lamina ball-bearing retainers (ARM) are made of a heat-treated aluminum alloy that combines lightness and strength.

Each retainer is quality inspected for dimensional tolerance and all burrs are removed prior to ball insertion.

Ball bearings are of the highest quality AAA1 Grade (25 millionth class), continually inspected to meet our exacting tolerance.

After the ball bearings have been inserted into the retainer, they are then staked using Lamina's unique method that allows free movement with maximum security.

After staking, the retainers are then scrubbed to remove all metal particles that could cause accelerated tracking and grooving in the post and bushing.

Ball bearings are placed in retainers in an off-line radial pattern that offers optimum life in high or low speed presses.

Ball-bearing retainers are fastened to the guide post by means of a set screw and slot in guide post and are interchangeable with other manufacturers using this method.

## Ball-Bearing Sleeve Bushings – Metric

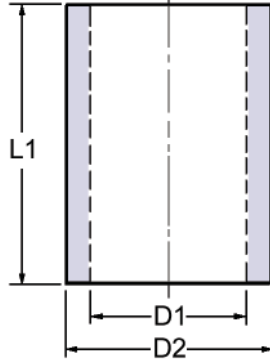

- Vacuum degassed chrome alloy steel
- Ground & honed to exact tolerance limits
- Top chamfered on I.D. to aid in alignment

Lengths up to 300mm – centerless ground  
 Lengths over 300mm – ground on centers

BALL-BEARING SLEEVE BUSHINGS – METRIC															
PART NUMBER	NOM PIN DIA	D1	D2	L1	PART NUMBER	NOM PIN DIA	D1	D2	L1						
ABM032075	32	41.977 41.969	54.005 53.995	75	ABM050175	50	63.975 63.967	81.005 80.995	175						
ABM032080				80	ABM050190				190						
ABM032090				90	ABM050200				200						
ABM032095				95	ABM050215				215						
ABM032100				100	ABM050230				230						
ABM032105				105	ABM050250				250						
ABM032115				115	ABM050280				280						
ABM032125				125	ABM050300				300						
ABM032140				140	ABM050330				330						
ABM032150				150	ABM050350				350						
ABM032165				165	ABM063150				150						
ABM032175				175	ABM063165				165						
ABM032200				220	ABM063175				175						
ABM032230				230	ABM063190				190						
ABM040100				40	49.977 49.969				65.005 64.995	100	ABM063200	63	76.975 76.967	95.005 94.995	200
ABM040105										105	ABM063215				215
ABM040115										115	ABM063230				230
ABM040120	120	ABM063250	250												
ABM040125	125	ABM063280	280												
ABM040135	135	ABM063300	300												
ABM040140	140	ABM063330	330												
ABM040150	150	ABM063350	350												
ABM040165	165	ABM080150	150												
ABM040175	175	ABM080165	165												
ABM040190	190	ABM080175	175												
ABM040200	200	ABM080190	190												
ABM040215	215	ABM080200	200												
ABM040230	230	ABM080215	215												
ABM040250	250	ABM080230	230												
ABM040280	280	ABM080250	250												
ABM040300	300	ABM080280	280												
ABM050125	50	63.975 63.967	81.005 80.995	125	ABM080300	80	93.975 93.967	112.005 111.995	300						
ABM050135				135	ABM080330				330						
ABM050140				140	ABM080350				350						
ABM050150				150	ABM080500				500						
ABM050165				165											

## Ball-Bearing Bushings – Tap Fit – Metric

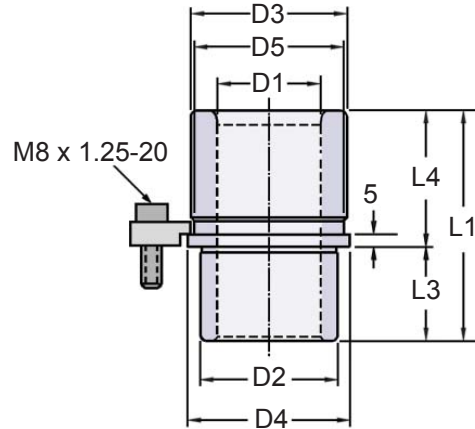

Demountable shoulder bushings offer all the advantages of straight sleeve bushings and combine them with the convenience of easy assembly and disassembly.

These clamp type bushings are meant to be wring fit into the die shoe and should never be forced or inserted by hammering.

X-40-Clamps and socket head screws are provided to hold the bushings in place.

BALL-BEARING BUSHINGS – DEMOUNTABLE – METRIC																			
PART NUMBER	NOM PIN DIA	D1	D2	D3	D4	D5	L1	L3	L4	PART NUMBER	NOM PIN DIA	D1	D2	D3	D4	D5	L1	L3	L4
ABGM032065							65		35	ABGM050075							75		40
ABGM032070							70		40	ABGM050090							90		55
ABGM032075							75		45	ABGM050095							95		60
ABGM032080							80		50	ABGM050100							100		65
ABGM032085							85		55	ABGM050110							110		75
ABGM032090							90		60	ABGM050115							115		80
ABGM032095	32	41.977	53.959	61	61	54.10	95	30	65	ABGM050125	50	63.975	80.959	91	91	84.15	125	35	90
ABGM032105		41.969	53.951				105		75	ABGM050135		63.967	80.951				135		100
ABGM032110							110		80	ABGM050140							140		105
ABGM032115							115		85	ABGM050155							155		120
ABGM032130							130		100	ABGM050165							165		130
ABGM032140							140		110	ABGM050180							180		145
ABGM032155							155		125	ABGM050190							190		155
ABGM040075							75		40	ABGM063125							125		90
ABGM040080							80		45	ABGM063140							140		105
ABGM040085							85		50	ABGM063155	63	76.975	94.960	105	105	98.43	155	35	120
ABGM040090							90		55	ABGM063165		76.967	94.952				165		130
ABGM040095							95		60	ABGM063180							180		145
ABGM040100							100		65	ABGM063190							190		155
ABGM040110	40	49.977	64.960	72	72	65.10	110	35	75	ABGM080125							125		90
ABGM040115		49.969	64.952				115		80	ABGM080140							140		105
ABGM040120							120		85	ABGM080155							155		120
ABGM040125							125		90	ABGM080165	80	93.975	111.960	122	122	115.90	165	35	130
ABGM040135							135		100	ABGM080180		93.967	111.952				180		145
ABGM040140							140		105	ABGM080190							190		155
ABGM040155							155		120										

## Ball-Bearing Guide Posts –Straight – Metric

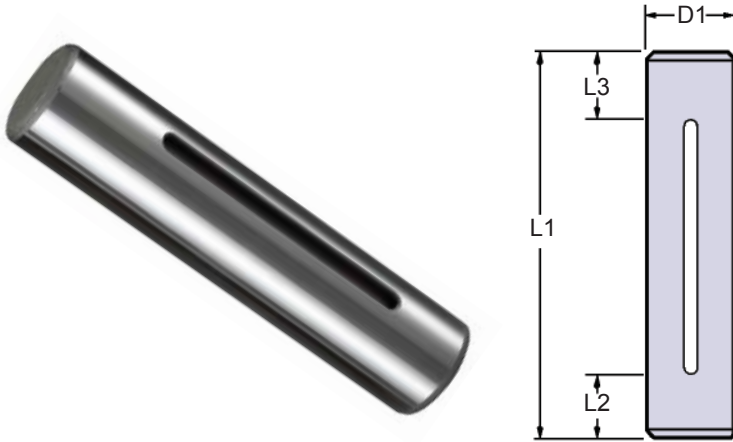

- Hardened chrome alloy steel
- Precision Ground

Lengths up to 300mm – centerless ground  
 Lengths over 300mm – ground on centers

BALL-BEARING GUIDE POSTS – METRIC																									
PART NUMBER	NOM PIN DIA	D1	L1	L2	L3	# of Slots	PART NUMBER	NOM PIN DIA	D1	L1	L2	L3	# of Slots												
APM032125	32	32.008 32.000	125	25.4	34.9	1	APM050215	50	50.008 50.000	215	47.6	57.2	2												
APM032135			135	25.4	34.9		APM050230							230	47.6	57.2									
APM032140			140	25.4	34.9		APM050240							240	47.6	57.2									
APM032145			145	25.4	34.9		APM050250							250	47.6	57.2									
APM032150			150	28.6	44.5		APM050265							265	47.6	57.2									
APM032165			165	28.6	44.5		APM050280							280	47.6	76.2									
APM032175			175	28.6	44.5		APM050290							290	47.6	76.2									
APM032190			190	28.6	44.5		APM050300							300	47.6	76.2									
APM032200			200	28.6	44.5		APM050315							315	47.6	76.2									
APM032215			215	28.6	44.5		APM050330							330	47.6	76.2									
APM032230			230	28.6	44.5		APM050360							360	47.6	76.2									
APM032250			250	28.6	57.2		APM050380							380	47.6	76.2									
APM032260			260	28.6	57.2		APM050400							400	47.6	76.2									
APM032280			280	28.6	57.2		APM050430							430	47.6	76.2									
APM032300			300	28.6	57.2		APM050460							460	47.6	76.2									
APM040125			40	40.008 40.000	125		34.9							33.3	1	APM063200	63	63.008 63.000	200	41.3	63.5	2			
APM040135					135		34.9							33.3		APM063215							215	41.3	63.5
APM040140					140		34.9							33.3		APM063230							230	41.3	63.5
APM040145	145	31.8			39.7	APM063240	240	60.3	76.2																
APM040150	150	31.8			39.7	APM063250	250	60.3	76.2																
APM040165	165	34.9			39.7	APM063265	265	60.3	76.2																
APM040175	175	34.9			50.8	APM063280	280	60.3	76.2																
APM040190	190	34.9			50.8	APM063300	300	60.3	76.2																
APM040200	200	34.9			50.8	APM063315	315	60.3	76.2																
APM040215	215	34.9			50.8	APM063330	330	60.3	76.2																
APM040230	230	41.3			63.5	APM063360	360	60.3	76.2																
APM040240	240	41.3			63.5	APM063380	380	60.3	76.2																
APM040250	250	41.3			63.5	APM063430	430	66.7	101.6																
APM040265	265	41.3			63.5	APM063500	500	66.7	101.6																
APM040280	280	41.3			63.5	APM080200	80	80.008 80.000	200	47.6	63.5	2													
APM040290	290	41.3			63.5	APM080215							215	47.6		63.5									
APM040300	300	41.3			63.5	APM080230							230	47.6		63.5									
APM040315	315	41.3			63.5	APM080250							250	73.0		76.2									
APM040330	330	41.3			63.5	APM080280							280	73.0		76.2									
APM040360	360	41.3			63.5	APM080300							300	73.0		76.2									
APM050150	50	50.008 50.000			150	34.9							38.1	2		APM080330							330	73.0	76.2
APM050165					165	44.5							47.6			APM080360							360	73.0	76.2
APM050175					175	44.5							47.6			APM080430							430	73.0	101.6
APM050190					190	44.5							47.6			APM080500							500	73.0	101.6
APM050200			200	44.5	47.6																				

## Ball-Bearing Guide Posts – Tap Fit – Metric

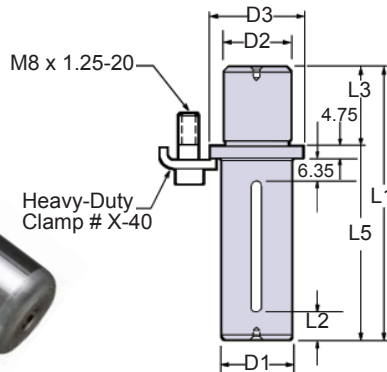

- Large savings in maintenance, repair costs and downtime
- Wide variety of sizes
- Long, trouble-free production runs
- Highest quality workmanship and materials
- "D2" dimension is finished ground

**BALL-BEARING GUIDE POSTS – METRIC – Tap Fit**

PART NUMBER	NOM PIN DIA	D1	D2	D3	L1	L2	L3	L5	PART NUMBER	NOM PIN DIA	D1	D2	D3	L1	L2	L3	L5
APGM032115	32	32.008 32.000	31.953 31.940	40	115	25.4	30	85	APGM050165	50	50.008 50.000	49.952 49.939	63	165	44.45	49	116
APGM032120					120	25.4		90	APGM050170					170	44.45		121
APGM032125					125	25.4		95	APGM050175					175	44.45		126
APGM032135					135	25.4		105	APGM050180					180	44.45		131
APGM032140					140	25.4		110	APGM050190					190	44.45		141
APGM032145					145	25.4		115	APGM050195					195	44.45		146
APGM032150					150	28.58		120	APGM050200					200	44.45		151
APGM032165					165	28.58		135	APGM050215					215	47.63		166
APGM032175					175	28.58		145	APGM050230					230	47.63		181
APGM032190					190	28.58		160	APGM050240					240	47.63		191
APGM032200					200	28.58		170	APGM050250					250	47.63		201
APGM032215					215	28.58		185	APGM050260					260	47.63		211
APGM032230					230	28.58		200	APGM050280					280	47.63		231
APGM032250					250	28.58		220	APGM050290					290	47.63		241
APGM032280					280	28.58		250	APGM050300					300	47.63		251
APGM032300					300	28.58		270	APGM050315					315	47.63		266
APGM040115					40	40.008 40.000		39.952 39.939	48					115	34.93		36
APGM040120	120	34.93	84	APGM050360			360			47.63	311						
APGM040125	125	34.93	89	APGM050380			380			47.63	331						
APGM040135	135	34.93	99	APGM050400			400			47.63	351						
APGM040140	140	31.75	104	APGM050430			430			47.63	381						
APGM040145	145	31.75	109	APGM050460			460			47.63	411						
APGM040150	150	31.75	114	APGM063200			200			41.28	151						
APGM040165	165	34.93	129	APGM063215			215			41.28	166						
APGM040175	175	34.93	139	APGM063230			230			41.28	181						
APGM040190	190	34.93	154	APGM063250			250			60.33	201						
APGM040200	200	34.93	164	APGM063280			280			60.33	231						
APGM040215	215	41.28	179	APGM063300			300			60.33	251						
APGM040230	230	41.28	194	APGM063330			330			60.33	281						
APGM040240	240	41.28	204	APGM063360			360			60.33	311						
APGM040250	250	41.28	214	APGM063430			430			66.68	381						
APGM040260	260	41.28	224	APGM063500			500			66.68	451						
APGM040280	280	41.28	244	APGM080200			200			47.6	138						
APGM040290	290	41.28	254	APGM080215	215	47.6	153										
APGM040300	300	41.28	264	APGM080230	230	47.6	168										
APGM040315	315	41.28	279	APGM080250	250	73.02	188										
APGM040330	330	41.28	294	APGM080280	280	73.02	218										
APGM040360	360	41.28	324	APGM080300	300	73.02	238										
APGM050140	50	50.008 50.000	49.952 49.939	63	140	34.93	49	91	APGM080330	80	80.008 80.000	79.952 79.939	93	330	73.02	62	268
APGM050145					145	34.93		96	APGM080360					360	73.02		298
APGM050150					150	34.93		101	APGM080430					430	73.02		368
APGM050155					155	44.95		106	APGM080500					500	73.02		438



**Lamina Components**  
38505 Country Club Drive, Suite 100  
Farmington Hills, Michigan 48331 USA  
Tel: 248-489-9122, 800-652-6462  
Fax: 248-553-6842, 800-406-4410

[www.anchorlamina.com](http://www.anchorlamina.com)  
email: [sales@lamina.com](mailto:sales@lamina.com)

