



TRUSTED SOLUTIONS AND INNOVATION

# CATALOG DIE SETS

- ◆ **Quality & performance**
- ◆ **Quick delivery**
- ◆ **Precision Components**



# CATALOG DIE SETS

## Service We Deliver and Quality You Can Depend On

**DANLY IEM** is a leading manufacturer of die sets and die component products supplied globally to the parts forming industry. Backed by years of tool and die experience, quality and innovation are some of the reasons why our name is respected throughout the world. We have taken the lead role in creating and bringing new products to customers and helping them find solutions that improve their operations. Based on the capabilities **DANLY IEM** offers, we can help you to meet the demands of quick deliveries, technical support, quality products and competitive prices. **DANLY IEM** and its' broad distribution channels and direct sales personnel will assist you in any way to make your product a better and more profitable one.

We understand the demanding schedules of die builders and production personnel and have developed efficient manufacturing processes to shorten product lead times as well as put inventory on our shelves so you can have it in your facility when you need it. Put the **DANLY IEM** network to work for you. We've got the service you've been looking for.

Included in our full line offering are both inch and metric size die sets and die components that are designed to numerous die standards including ISO, NAAMS, JIS and many large automotive and appliance manufacturers' standards. The complete product offering includes:

- Ball bearing and friction style die sets including custom and catalog sets
- Machined plate
- Guide posts & bushings
- ISO and JIS Die springs
- In-die tapping units for both mechanical and hydraulic presses
- Formathane® Urethane springs, strippers, sheets, bars, rods and die cover film
- Diemakers' supplies such as pry bars, dowel pins, hoist rings, clamps and fasteners
- Standard and self-lubricating wear product including wear plate, wear strips, gibs, keeper plates and guide blocks
- Cam units, including Mini™, Aerial and Die Mount styles
- Accu-Bend™ Rotary Benders
- Standard and Ball lock punches and retainers
- Air presses
- Pad retainers

# Catalog Die Sets

---

## TABLE OF CONTENTS

## PAGE NUMBER

General Information	2
Back Posts	4
Rectangular Die Sets - Rectangular Back Posts	8
Rectangular Die Sets - Rectangular Two Post	10
Rectangular Die Sets - Rectangular Four Post	12
Kick Press Semi-Steel Die Sets	14
Center Posts	16

# General Information

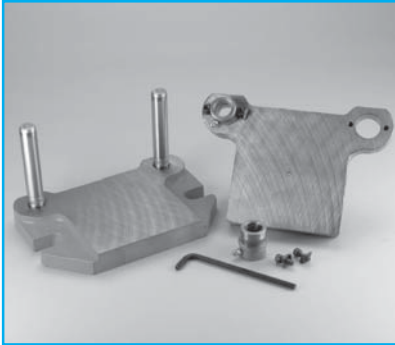

## Ease of Assembly

The demountable bushings are assembled in the punch holder with easily mounted clamps that serve to maintain perfect alignment of the bushings, with the bore perpendicular to the ground surface of the punch holder. The use of clamps and screws gives the demountable bushings four times the holding power of pressed-in bushings.

The precision fit of the guide posts and the demountable bushings also makes for ease of assembly and disassembly in die making and repair. The demountable bushing set is assembled and disassembled with complete ease because the demountable bushings in the punch holder fit the Microme guide posts in the die holder with positive accuracy. This is a distinct advantage in the die making, grinding and repairing dies.



## A Complete Line of Precision Bushings

**Danly** offers a complete line of demountable shoulder and short shoulder bushings in hardened steel, bronze-plated and bronze shoulder bushings.



## Microme Guide Posts

The Microme guide posts have a very high resistance to wear and their super smooth finish helps to guarantee precision performance. Guide posts are pressed in from the bottom or underside of the die holder and can be removed for die work or die grinding and reinserted accurately, with no surface damage.



## Lubrication System for Guide Posts and Bushings

**Danly** catalog die sets are designed for easy, fast lubrication. Note in the drawing at left how the shoulder of the bushing is equipped with a standard fitting which can be easily reached with a lubrication gun. Once the grease is injected into the bushings, it reaches the figure 8 oil grooves and protects the bushing and post from wear.

# General Information

## All Horizontal Surfaces are Precision Ground to Assure a Flat, True Working Surface

All surfaces are ground to precision standards to assure true working surfaces. The top surface of the punch holder is vented.

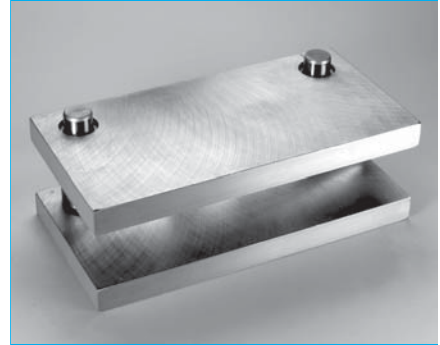

## Integral Welded Shank on All-Steel Sets

On all-steel catalog sets, the shank is an integral part of the punch holder. This construction features a high-strength 100% integral unit suitable for deep counter-boring or knockout holes. Semi-steel sets regularly furnished with shanks have an integrally cast shank.

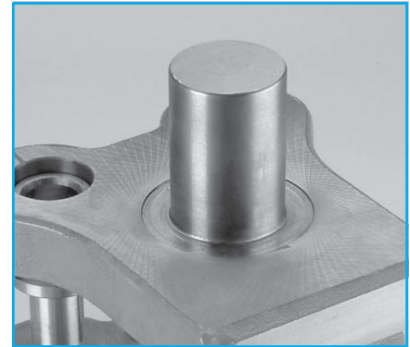

## Easier, Faster Clamping

**Danly** all-steel die sets with the “A” dimension 20” or more are furnished with clamping holes rather than clamping flanges. The illustration shows an all-steel die holder clamping method.

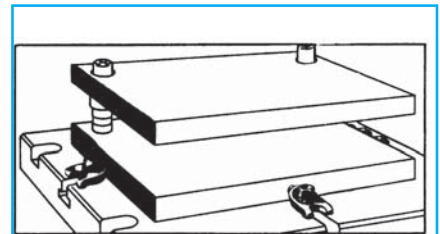

See page 8 for a more detailed description.

## Quality, Performance, Economy with Precise Fit

The **Danly** demountable bushing die sets offer the ultimate in quality, performance and economy. These demountable bushing die sets are typical of **Danly's** consistent leadership in the die set field. The superiority of **Danly** demountable bushing die sets is based on a method of die set manufacture and assembly that produces a precise fit between the guide posts and bushings. Guide posts and bushings are prefitted to dimensions, within tolerance, and furnished as matched units within each die set.



# Back Posts

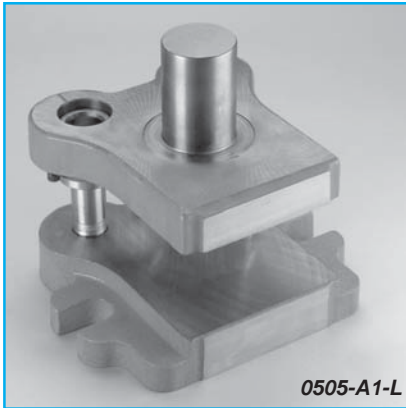

## Product Features

- ◆ Available with a variety of bushing and guide post types
- ◆ Meets ANSI B 5.25 Standards
- ◆ Front and rear edges are machined parallel to guide posts for ease in die building
- ◆ Shanks available upon request



## WHEN ORDERING

1. Specify quantity and catalog number.
2. Specify type of **DANLY** bushing. Unless otherwise specified, these sets are assembled with demountable steel shoulder bushings.
3. Specify length "L" from bottom of the die holder to top of guide post "O".
4. Specify diameter of punch shank. Punch shanks are integral and are available in the following sizes:

- ◆ 1-1/2" diameter x 2-1/8" long
- ◆ 1-9/16" diameter x 2-1/8" long
- ◆ 2" diameter x 2-7/8" long

Sets are also available without shanks. Special shanks can be furnished at additional cost.

5. Specify thickness combinations if other than listed. Other thicknesses are furnished at additional cost.
6. Specify how shipment should be made.

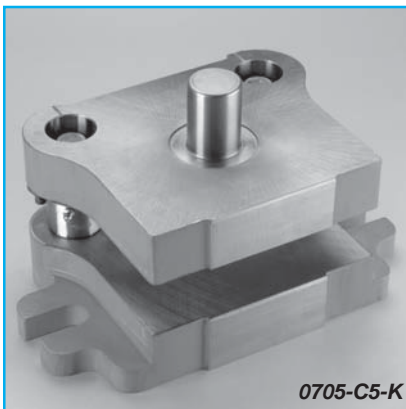
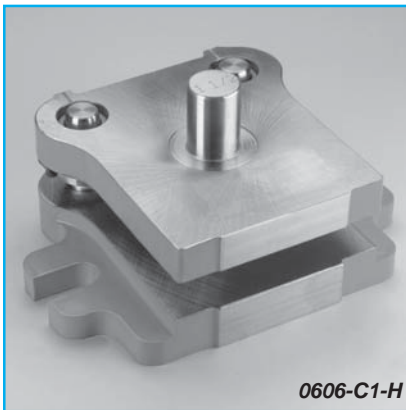

# Back Posts

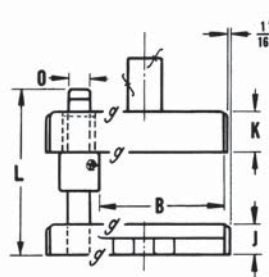
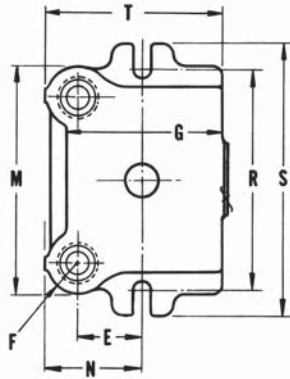
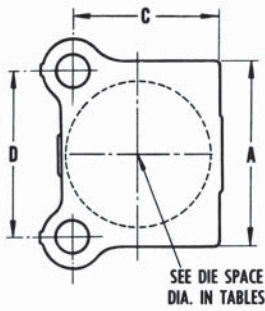

CLAMP ASSEMBLY FOR DEMOUNTABLE BUSHINGS

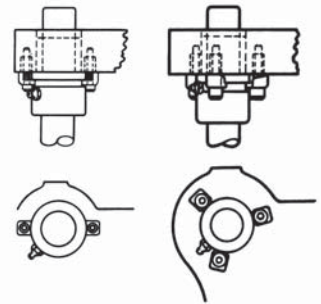

Catalog Numbers			Die Space		Diam.	Thickness		General Dimensions																													
Semi-Steel	Semi-Steel PH w/ Steel DH	All Steel	Left to Right	Front to Back	For Round Dies	Die Holder	Punch Holder	For bushing and guide post specifications, see our Diemakers' Supplies catalog. Sizes stocked are for "O" dimension.																													
			A	B		J	K	C	D	E	F	G	M	N	O	R	S	T																			
0303-A1	0303-B1	0303-C1	3	3	3	1	1	3-5/8	3-1/4	1-3/4	1	4-1/4	5-3/8	2-7/8	3/4	5	6-3/4	4-13/16																			
-	0303-B4	0303-C4				1-1/4																															
0403-A1	0403-B1	0403-C1	4	3	3-1/4	1-1/4	1	3-3/4	3-1/4	1-3/4	1-3/16	4-3/8	5-3/4	3-1/16	7/8	6-1/4	8	5-1/8																			
0404-A1	0404-B1	0404-C1				1-3/8													1-1/4	4-7/8	2-7/16	5-3/4	6-1/8	3-3/4	1	6	7-3/4	6-3/16									
-	0404-B4	0404-C4				1-3/4																							4-7/8	2-7/16	1-3/8	5-3/4	6-1/8	3-3/4	6	7-3/4	6-3/16
-	-	0406-C1				1-1/2																							6-7/8	5-1/8	3-1/4	7-1/2	8	4-11/16	6-1/4	8-7/8	8-5/16
0504-A1	0504-B1	0504-C1	5	4	4-1/2	1-3/8	1-1/4	4-7/8	4	2-3/8	1-3/8	5-3/8	7	4-1/8	1	7	8-3/4	7-5/16																			
-	0504-B4	0504-C4				1-3/4													4-7/8	2-3/8	3-13/16	3-13/16	6-5/16														
0505-A1	0505-B1	0505-C1				1-1/2													5-7/8	4	2-11/16	1-3/8	6-3/8	7	4-1/8	1	7	8-3/4	7-5/16								
-	0505-B4	0505-C4				2																								1-1/4							
-	-	0505-C5				2																								1-3/4							
-	-	0508-C1	8	1-1/2	1-1/4	8-7/8	6-1/2	4-1/4	9-1/2	9-3/8	5-11/16	9-5/8	10-5/16																								
0604-A1	0604-B1	0604-C1	6-1/2	4	5	1-1/2	1-1/4	4-7/8	5-1/8	2-1/8	1-3/8	5-1/2	8	4-5/8	1	8-5/8	11-1/4	8-5/16																			
-	0604-B4	0604-C4				1-3/4													4-7/8	2-1/8	5-1/2	3-9/16	3-9/16	6-5/16													
0606-A1	0606-B1	0606-C1				1-1/2													6-7/8	5-1/8	3-3/16	1-3/8	7-1/2	8	4-5/8	1	8-5/8	11-1/4	8-5/16								
-	0606-B4	0606-C4				2																								1-1/4							
-	-	0606-C5				2																								1-3/4							
-	-	0609-C1				9																								1-1/2	1-3/8	10	7-3/4	4-3/4	1-5/8	10-5/8	11-1/8
-	-	0705-C1	7-1/2	5	5-3/4	1-1/2	1-1/4	5-7/8	6-1/2	2-3/4	1-3/8	6-1/2	9-3/8	4-3/16	1	9-5/8	12-1/4	7-5/16																			
-	0705-C2	1-1/2				1-3/4																															
-	0705-C4	2				1-1/4																															
-	0705-C5	2				1-3/4																															

NOTE: All dimensions are in inches, unless otherwise noted.

# Back Posts

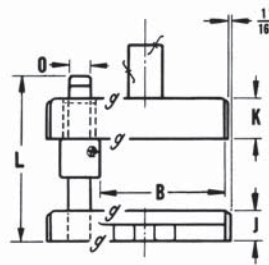
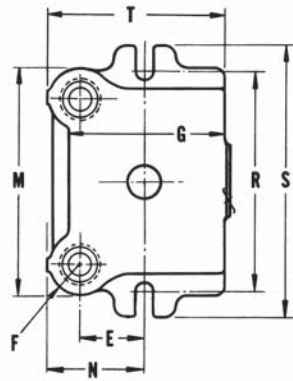
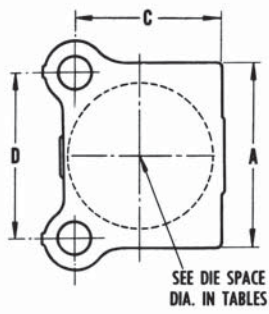

CLAMP ASSEMBLY FOR DEMOUNTABLE BUSHINGS

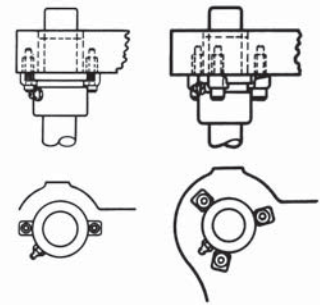

Catalog Numbers	Die Space		Diam. For Round Dies	Thickness		General Dimensions											
	Left to Right	Front to Back		Die Holder	Punch Holder	<i>For bushing and guide post specifications, see our Diemakers' Supplies catalog. Sizes stocked are for "O" dimension.</i>											
	A	B		J	K	C	D	E	F	G	M	N	O	R	S	T	
0707-C1	7-1/2	7	7-1/2	1-1/2	1-1/4	7-7/8	6-1/2	3-11/16	1-3/8	8-1/2	9-3/8	5-1/8	1	9-5/8	12-1/4	9-5/16	
0707-C2				1-1/2	1-3/4												
0707-C4				2	1-1/4												
0707-C5				2	1-3/4												
0710-C1		10	-	1-5/8	1-3/8	11	9-1/8	5-1/4	1-5/8	11-5/8	12-1/2	6-15/16	1-1/4	9-5/8	12-1/4	12-11/16	
0804-C1	8-1/2	4	-		1-1/4	4-7/8		2-5/16		5-1/2		3-7/8				6-7/16	
0806-C1				1-1/2	1-1/4												
0806-C2					1-3/4	6-7/8	7-3/4	3-1/8	1-3/8	7-1/2	10-5/8	4-11/16	1	10-5/8	13-1/4	8-7/16	
0806-C4		2-1/4	1-1/4														
0806-C5		2-1/4	1-3/4														
0808-C1		1-1/2	1-1/4														
0808-C2		8	8-1/2		1-1/2	1-3/4	8-7/8		4-3/16		9-1/2	10-5/8	5-3/4	1	10-5/8	13-1/4	10-7/16
0808-C4					2	1-1/4											
0808-C5					2	1-3/4											
0811-C1			11	-	1-3/4	1-1/2	12	10-1/4	5-3/4	1-5/8	12-7/8	13-5/8	7-7/16	1-1/4	10-5/8	13-1/4	13-11/16
1005-C1	10	5	-	1-1/2		6		3-5/16		6-5/8		5		12-1/4	14-7/8	7-11/16	
1005-C4				2	1-3/8												6
1007-C1		7			1-5/8		8	9-1/8	3-9/16	1-5/8	8-5/8	12-1/2	5-1/4	1-1/4	12-1/8	14-3/4	9-11/16
1007-C2					1-5/8	1-3/4											
1007-C4					2-1/4	1-3/8											
1007-C5					2-1/4	1-3/4	11	10-1/4	5-1/4	1-5/8	11-7/8	13-5/8	6-15/16	1-1/4	12-1/4	14-7/8	12-11/16
1010-C1		10	10	1-5/8	1-3/8												
1010-C2				1-5/8	1-3/4												
1010-C4				2-1/4	1-3/8												
1010-C5			2-1/4	1-3/4													

NOTE: All dimensions are in inches, unless otherwise noted.

# Back Posts

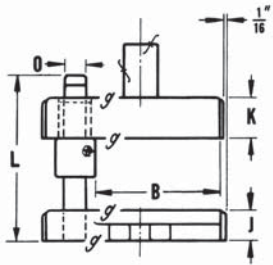
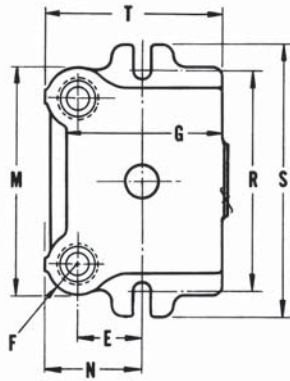
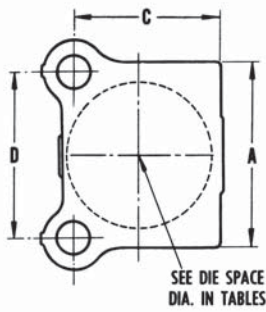

CLAMP ASSEMBLY FOR DEMOUNTABLE BUSHINGS

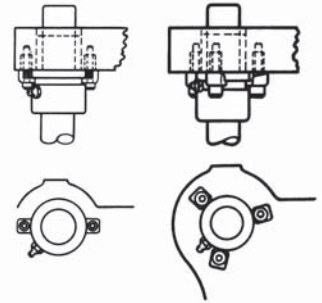

Catalog Numbers	Die Space		Diam.		Thickness		General Dimensions										
	Left to Right	Front to Back	For Round Dies	Die Holder	Punch Holder	For bushing and guide post specifications, see our Diemakers' Supplies catalog. Sizes stocked are for "O" dimension.											
All Steel	A	B		J	K	C	D	E	F	M	N	O	R	S	T		
1107-C1	11-1/4	7	8	1-3/4	1-1/2	8-1/8	10-1/4	4	1-5/8	13-5/8	5-11/16	1-1/4	13-1/2	16-1/8	9-13/16		
1109-C1		9	10	1-3/4	1-1/2	10	10-1/4	4-7/8	1-5/8	13-5/8	6-9/16	1-1/4	13-1/2	16-1/8	11-11/16		
1204-C1	12-1/2	4	-	1-1/2	1-1/2	5	10-1/4	2-9/16	1-5/8	13-5/8	4-1/4	1-1/4	14-3/4	17-3/8	6-11/16		
1206-C1		6	-	1-1/2		7-1/8		4								5-11/16	8-13/16
1206-C4		6	-	2	7-1/8	4	5-11/16	8-13/16									
1210-C1		10	10-3/4	1-3/4	1-5/8	11-1/8	14	5-3/8	2	18	7-1/2	1-1/2	14-5/8	17-1/4	13-1/4		
1210-C4		10	10-3/4	2-1/2	1-5/8	11-1/8		5-3/8								7-1/2	13-1/4
1212-C1		12	12-1/2	1-3/4	1-3/4	13-1/8		6-3/8								8-1/2	15-1/4
1212-C4		12	12-1/2	2-1/2	1-3/4	13-1/8		6-3/8								8-1/2	15-1/4
1410-C1	14	10	11-1/4	1-3/4	1-5/8	11-1/4	14	5-5/8	2	18	7-3/4	1-1/2	16-7/8	19-1/2	13-3/8		
1505-C1	15	5	-	1-1/2	1-1/2	6-1/8	14	2-15/16	2	18	5-1/16	1-1/2	17-1/4	19-7/8	8-1/4		
1507-C1		7	-	1-1/2		8-1/8		4-3/8								6-1/2	10-1/4
1507-C4		7	-	2	8-1/8	4-3/8	6-1/2	10-1/4									
1509-C1		9	-	1-1/2	10-1/8	5	7-1/8	12-1/4									
1805-C1	18	5	-	1-1/2	1-1/2	6-1/8	16-3/4	3-3/16	2	20-3/4	5-5/16	1-1/2	20-1/8	22-3/4	8-1/4		
1808-C1		8	-	1-1/2	1-1/2	9-1/8	16-3/4	4-13/16	2	20-3/4	6-15/16	1-1/2	20-1/8	22-3/4	11-1/4		

NOTE: All dimensions are in inches, unless otherwise noted.

# Rectangular Die Sets – Rectangular Back Posts



2209-RC1

## Product Features

- ◆ Available with a variety of bushing and guide post types
- ◆ Meets ANSI B 5.25 Standards
- ◆ Front and rear edges are machined parallel to guide posts for ease in die building
- ◆ Shanks available upon request

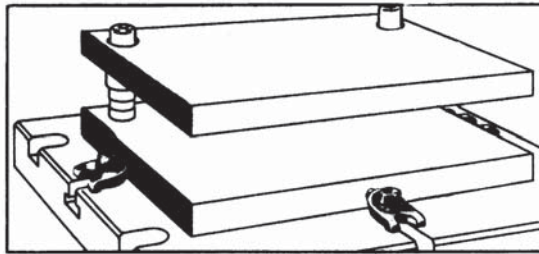

### CLAMPING METHOD FOR ALL-STEEL HOLDER

The illustration above shows the space saving method for clamping an all-steel die holder where the bolster plate is equipped with T-slots. Note the lack of interference for stock feed. See the Diemakers' Supplies Catalog for a complete description of clamps and clamping methods.

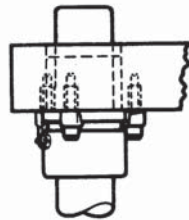

1 1/2" Bushing in  
Steel Punch Holder

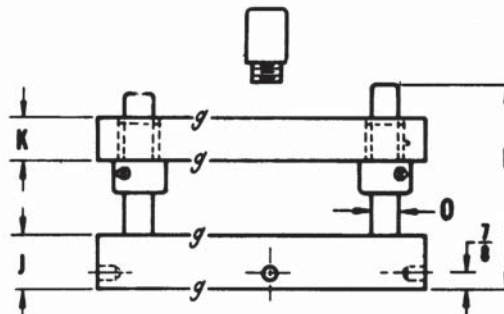
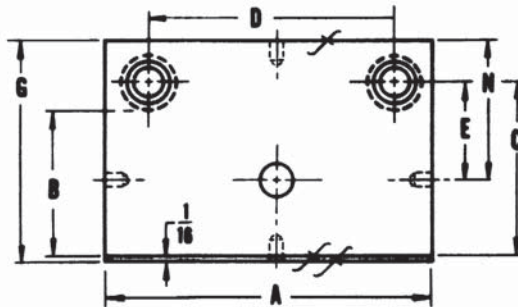

# Rectangular Die Sets – Rectangular Back Post

## WHEN ORDERING

1. Specify quantity and catalog number.
2. Specify type of **Danly** bushing. Unless otherwise specified, these sets are assembled with demountable steel shoulder bushings.
3. Specify length “L” from bottom of the die holder to top of guide post “O”.
4. Specify size of shank, if ordered. These sets are regularly furnished without shanks. Inserted steel shanks in the sizes below are available at additional cost:
  - ◆ 1-1/2" diameter x 2-1/8" long
  - ◆ 1-9/16" diameter x 2-1/8" long
  - ◆ 2" diameter x 2-7/8" long
  - ◆ 2-1/2" diameter x 2-7/8" long
  - ◆ 3" diameter x 2-7/8" long
5. Specify thickness combinations if other than listed. Other thicknesses are furnished at additional cost.
6. Specify how shipment should be made.

Catalog Numbers	Die Space		Thickness		General Dimensions					
All Steel	Left to Right	Front to Back	Die Holder	Punch Holder	<i>For bushing and guide post specifications, see our Diemakers' Supplies catalog. Sizes stocked are for "O" dimension.</i>					
	A	B	J	K	C	D	E	G	N	O
2005-RC1	20-3/4	5	1-3/4	1-1/2	6-1/8	16-3/4	3-5/16	8-1/4	5-7/16	1-1/2
2008-RC1		8			9-1/8		4-15/16	11-1/4	7-1/16	
2012-RC1		12			13-1/8		6-1/4	15-1/4	8-3/8	
2209-RC1	22-1/2	9	1-3/4	1-1/2	10-1/8	16-3/4	5-7/16	12-1/4	7-9/16	1-1/2
2507-RC1	25	7	1-3/4	1-1/2	8-1/8	19-1/2	4-5/16	10-1/4	6-7/16	1-1/2
2511-RC1		11			12-1/8		6-7/16	14-1/4	8-9/16	

**NOTE:** All dimensions are in inches, unless otherwise noted.

# Rectangular Die Sets – Rectangular Two Post



## Product Features

- ◆ Available with a variety of bushing and guide post types
- ◆ Meets ANSI B 5.25 Standards
- ◆ Front and rear edges are machined parallel to guide posts for ease in die building
- ◆ Shanks available upon request

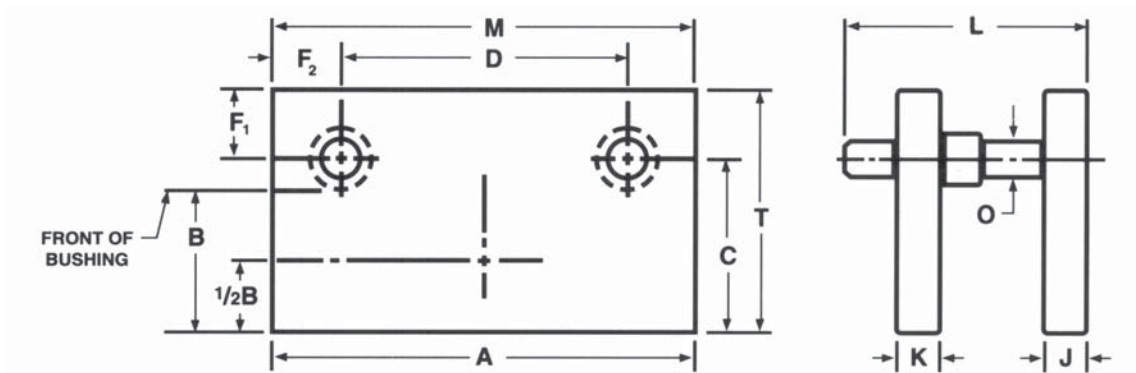

Catalog Numbers	Die Space		Thickness		General Dimensions							
	Left to Right	Front to Back	Die Holder	Punch Holder	For bushing and guide post specifications, see our Diemakers' Supplies catalog. Sizes stocked are for "O" dimension.							
All Steel	A	B	J	K	O	C	D	M	T	F <sub>1</sub>	F <sub>2</sub>	
1006-2C-1	10-1/2	6	1-1/2	1-1/4	1	7	7-3/4	10-1/2	8-1/2	1-1/2	1-3/8	
1006-2C-2			1-1/2	1-1/2								
1006-2C-4			2	1-1/4								
1006-2C-5			2	1-1/2								
1206-2C-1	12-1/2	6	1-1/2	1-1/2	1-1/4	7	9-1/8	12-1/2	8-5/8	1-5/8	1-11/16	
1206-2C-2			1-1/2	2								
1206-2C-4			2	1-1/2								
1206-2C-5			2	2								
1208-2C-1		8	8	1-1/2	1-1/2	1-1/4	9	9-1/8	12-1/2	10-5/8	1-5/8	1-11/16
1208-2C-2				1-1/2	2							
1208-2C-4				2	1-1/2							
1208-2C-5				2	2							
1210-2C-1		10	10	1-1/2	1-1/2	1-1/2	11-1/8	12-1/2	12-1/2	13	1-7/8	1-11/16
1210-2C-2				1-1/2	2							
1210-2C-4				2	1-1/2							
1210-2C-5				2	2							

**NOTE:** All dimensions are in inches, unless otherwise noted.

# Rectangular Die Sets – Rectangular Two Post

Catalog Numbers	Die Space		Thickness		General Dimensions						
	Left to Right	Front to Back	Die Holder	Punch Holder	For bushing and guide post specifications, see our Diemakers' Supplies catalog. Sizes stocked are for "O" dimension.						
					A	B	J	K	O	C	D
1406-2C-1	14	6	1-1/2	1-1/2	1-1/4	7	10-1/4	14	8-5/8	1-5/8	1-7/8
1406-2C-2			1-1/2	2							
1406-2C-4			2	1-1/2							
1406-2C-5			2	2							
1408-2C-1		8	1-1/2	1-1/2	1-1/4	9	10-1/4	14	10-5/8	1-5/8	1-7/8
1408-2C-2			1-1/2	2							
1408-2C-4			2	1-1/2							
1408-2C-5		2	2	2	1-1/2	11-1/8	10-1/4	14	13	1-7/8	1-7/8
1410-2C-1			1-1/2	1-1/2							
1410-2C-2		10	1-1/2	2	1-1/2	11-1/8	10-1/4	14	13	1-7/8	1-7/8
1410-2C-4			2	1-1/2							
1410-2C-5			2	2							
1412-2C-1		12	1-1/2	1-1/2	1-1/2	13-1/8	10-1/4	14	15	1-7/8	1-7/8
1412-2C-2			1-1/2	2							
1412-2C-4			2	1-1/2							
1412-2C-5	2		2								
1607-2C-1	16	7	1-1/2	1-1/2	1-1/2	8-1/8	12-1/4	16	10	1-7/8	1-7/8
1607-2C-2			1-1/2	2							
1607-2C-4			2	1-1/2							
1607-2C-5		9	2	2	1-1/2	10-1/8	12-1/4	16	12	1-7/8	1-7/8
1609-2C-1			1-1/2	1-1/2							
1609-2C-2			1-1/2	2							
1609-2C-4		11	2	1-1/2	1-1/2	12-1/8	12-1/4	16	14	1-7/8	1-7/8
1609-2C-5			2	2							
1611-2C-1		11	1-1/2	1-1/2	1-1/2	12-1/8	12-1/4	16	14	1-7/8	1-7/8
1611-2C-2			1-1/2	2							
1611-2C-4			2	1-1/2							
1611-2C-5			2	2							
1806-2C-1	18	6	1-1/2	1-1/2	1-1/2	7-1/8	18	18	9	1-7/8	2
1806-2C-2			1-1/2	2							
1806-2C-4			2	1-1/2							
1806-2C-5			2	2							
1808-2C-1		8	1-1/2	1-1/2	1-1/2	9-1/8	14	18	11	1-7/8	2
1808-2C-2			1-1/2	2							
1808-2C-4			2	1-1/2							
1808-2C-5		2	2	2	1-1/2	11-1/8	14	18	13	1-7/8	2
1810-2C-1			1-1/2	1-1/2							
1810-2C-2		10	1-1/2	2	1-1/2	11-1/8	14	18	13	1-7/8	2
1810-2C-4			2	1-1/2							
1810-2C-5			2	2							
1812-2C-1		12	1-1/2	1-1/2	1-1/2	13-1/8	14	18	15	1-7/8	2
1812-2C-2			1-1/2	2							
1812-2C-4			2	1-1/2							
1812-2C-5			2	2							
1814-2C-1		14	2	2	1-1/2	15-1/8	14	18	17	1-7/8	2

**NOTE:** All dimensions are in inches, unless otherwise noted.

# Rectangular Die Sets – Rectangular Four Post

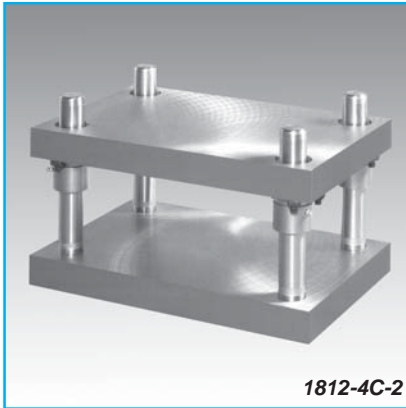

## Product Features

- ◆ Available with a variety of bushing and guide post types
- ◆ Meets ANSI B 5.25 Standards
- ◆ Front and rear edges are machined parallel to guide posts for ease in die building
- ◆ Shanks available upon request

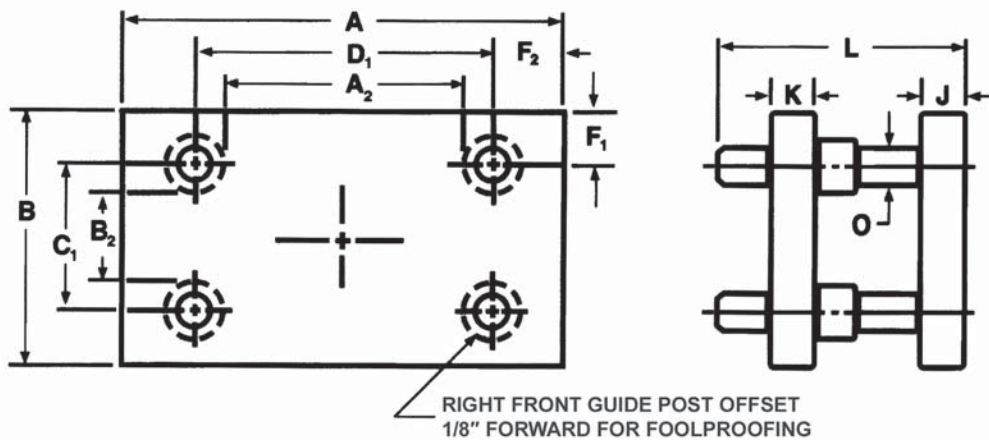

Catalog Numbers	Die Space		Thickness		General Dimensions						
	Left to Right	Front to Back	Die Holder	Punch Holder	<i>For bushing and guide post specifications, see our Diemakers' Supplies catalog. Sizes stocked are for "O" dimension.</i>						
All Steel	A	B	J	K	O	C <sub>1</sub>	D <sub>1</sub>	B <sub>2</sub>	A <sub>2</sub>	F <sub>1</sub>	F <sub>2</sub>
1008-4C-1	10	8	1-1/4	1	1	5-1/8	6-3/4	3-1/4	4-7/8	1-7/16	1-5/8
1008-4C-2			1-1/4	1-1/4							
1008-4C-4				1							
1008-4C-5			1-1/4								
1010-4C-1		10	10	1-1/2				1-1/4			
1010-4C-2		1-1/2									
1010-4C-4		2		1-1/4							
1010-4C-5		2		1-1/2							
1208-4C-1	12	8	1-1/4	1	1	5-1/8	8-3/4	3-1/4	6-7/8	1-7/16	1-5/8
1208-4C-2			1-1/4	1-1/2							
1208-4C-4				1							
1208-4C-5			1-1/2	1-1/2							
1210-4C-1		10	10					1-1/4			
1210-4C-2		1-1/2									
1210-4C-4		2		1-1/4							
1210-4C-5		2		1-1/2							

**NOTE:** All dimensions are in inches, unless otherwise noted.

# Rectangular Die Sets – Rectangular Four Post

Catalog Numbers	Die Space		Thickness		General Dimensions											
	Left to Right	Front to Back	Die Holder	Punch Holder	<i>For bushing and guide post specifications, see our Diemakers' Supplies catalog. Sizes stocked are for "O" dimension.</i>											
All Steel	A	B	J	K	O	C	D	B <sub>2</sub>	A <sub>2</sub>	F <sub>1</sub>	F <sub>2</sub>					
1212-4C-1	12	12	1-1/2	1-1/4	1	8-3/4	8-5/8	6-5/8	6-1/2	1-5/8	1-11/16					
1212-4C-2			1-1/2	1-1/2												
1212-4C-4			2	1-1/4												
1212-4C-5			2	1-1/2												
1410-4C-1	14	10	1-1/2	1-1/4	1-1/4	6-3/4	10-5/8	4-5/8	8-1/2	1-5/8	1-11/16					
1410-4C-2			1-1/2	1-1/2												
1410-4C-4			2	1-1/4												
1410-4C-5			2	1-1/2												
1412-4C-1		12	1-3/4	1-1/2		8-3/4		6-5/8								
1412-4C-2			1-3/4	2												
1412-4C-4			2	1-1/2												
1412-4C-5			2	2												
1610-4C-1	16	10	1-1/2	1-1/2	1-1/4	6-3/4	12-5/8	4-5/8	10-1/2	1-5/8	1-11/16					
1610-4C-2			1-1/2	2												
1610-4C-4			2	1-1/2												
1610-4C-5			2	2												
1612-4C-1		12	1-1/2	1-1/2		8-3/4		6-5/8								
1612-4C-2			1-1/2	2												
1612-4C-4			2	1-1/2												
1612-4C-5			2	2												
1812-4C-1	18	12	2	1-3/4	1-1/4	8-3/4	14-5/8	6-5/8	12-1/2	1-5/8	1-11/16					
1812-4C-2			2	2												
1812-4C-4			2-1/2	1-3/4												
1812-4C-5			2-1/2	2												
1814-4C-1		14	1-3/4	1-1/2		1-1/2		10-1/4				14	7-7/8	11-5/8	1-7/8	2
1814-4C-2			1-3/4	2												
1814-4C-4			2	1-1/2												
1814-4C-5			2	2												
2012-4C-1	20	12	2	1-1/2	1-1/2	8-1/4	16	5-7/8	13-5/8	1-7/8	2					
2012-4C-2			2	2												
2012-4C-4			2-1/2	1-1/2												
2012-4C-5			2-1/2	2												
2014-4C-1		14	2	2		10-1/4		7-7/8								
2014-4C-4			2-1/2	2												
2016-4C-1		16	2	2		12-1/4		9-7/8								
2416-4C-1		24	16	1-3/4		1-1/2		1-1/2				12-1/4	20	9-7/8	17-5/8	1-7/8
2416-4C-2	1-3/4			2												
2416-4C-4	2-1/2			1-1/2												
2416-4C-5	2-1/2			2												

**NOTE:** All dimensions are in inches, unless otherwise noted.

# Kick Press Semi-Steel Die Sets

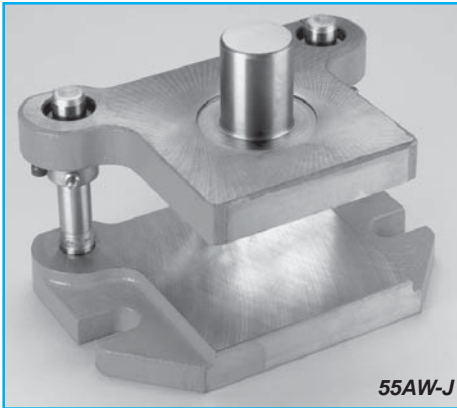

## Product Features

- ◆ Available with a variety of bushing and guide post types
- ◆ Meets ANSI B 5.25 Standards
- ◆ Front and rear edges are machined parallel to guide posts for ease in die building
- ◆ Shanks available upon request

## WHEN ORDERING

1. Specify quantity and catalog number.
2. Specify type of **Danly** bushing. Unless otherwise specified, these sets are assembled with steel short shoulder bushings.
3. Specify length "L" from bottom of the die holder to top of guide post "O".
4. Specify diameter of punch shank. Punch shanks are integral and are available in the following sizes:
  - ◆ 13/16" diameter x 1-7/16" long
  - ◆ 1" diameter x 1-7/16" long
  - ◆ 1-1/2" diameter x 2" long
  - ◆ 1-9/16" diameter x 2" long
5. Specify how shipment should be made.

# Kick Press Semi-Steel Die Sets

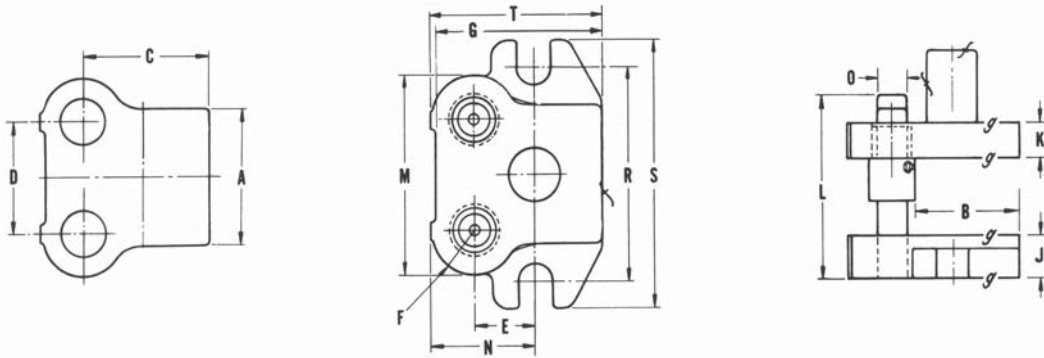

Catalog Numbers Semi-Steel	Die Space		Diameter for Round Dies		Thickness		General Dimensions											Punch Shank Diameter Small
	Left to Right	Front to Back	Die Holder	Punch Holder	Die Holder	Punch Holder	<i>For bushing and guide post specifications, see our Diemakers' Supplies catalog. Sizes stocked are for "O" dimension.</i>											
	A	B			J	K	C	D	E	F	G	M	N	O	R	S	T	
0202-GA-1	2-9/16	2-1/2	2-1/2	2-1/2	15/16	3/4	2-7/8	2-7/8	1-5/8	3/4	3-3/8	4-3/8	2-1/4	1/2	4	5-1/2	3-5/8	1" Dia. x 1-1/2" LG.
0403-GA-1	4	3	3-3/8	3-3/8	1	3/4	3-5/8	3-1/4	1-13/16	1	3-5/8	5-3/8	2-7/8	3/4	5	6	4-11/16	1" Dia. x 1-1/4" LG.
0604-GA-1	5-1/2	3-7/8	4	4	15/16	7/8	4-1/2	5-1/8	1-15/16	1	4-9/16	7-1/4	2-3/4	3/4	6-3/4	7-3/4	5-5/16	—

**NOTE:** All dimensions are in inches, unless otherwise noted.

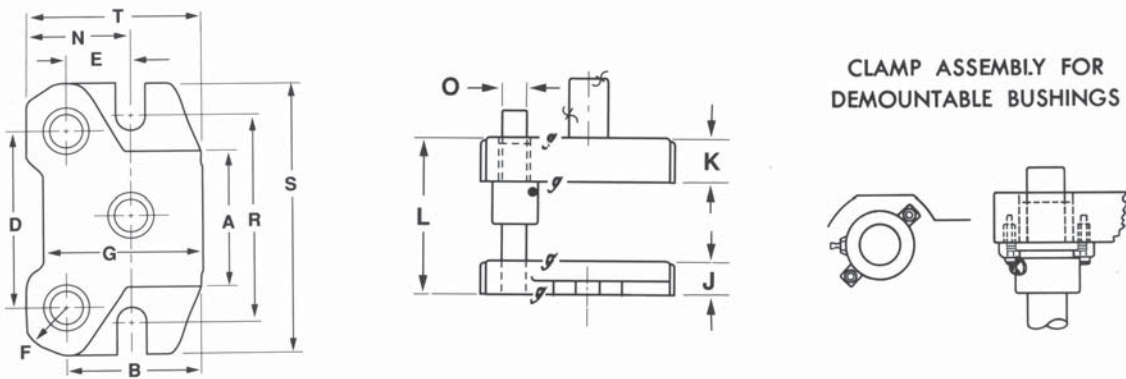

Catalog Numbers	Die Space		Thickness		General Dimensions									Punch Shank Diameter
	Left to Right	Front to Back	Die Holder	Punch Holder	<i>For bushing and guide post specifications, see our Diemakers' Supplies catalog. Sizes stocked are for "O" dimension.</i>									
	A	B	J	K	D	E	F	G	N	O	R	S	T	
33-AW	3	3	1	1	4	1-1/2	1-1/16	3-3/8	2-3/8	3/4	5	6-3/4	3-7/8	
44-AW	4	4			5-1/8	2		4-3/8	2-7/8		6	7-1/2	4-7/8	
54-AW	5	4			6-1/2	2		4-3/8	2-7/8		7	8-3/4	4-7/8	
55-AW	5	5			6-1/2	2-1/2		5-3/8	3-3/8		7	8-3/4	5-7/8	
64-AW	6	4			7-3/4	2		4-3/8	2-7/8		8	9-3/4	4-7/8	
66-AW	6	6			7-3/4	3		6-3/8	3-7/8		8	9-3/4	6-7/8	

Punch shanks are integral and are available in the following sizes:  
 ♦ 13/16" diameter x 1-7/16" long  
 ♦ 1" diameter x 1-7/16" long  
 ♦ 1-1/2" diameter x 2" long  
 ♦ 1-9/16" diameter x 2" long

**NOTE:** All dimensions are in inches, unless otherwise noted.

# Center Posts



## Product Features

- ◆ Available with a variety of bushing and guide post types
- ◆ Meets ANSI B 5.25 Standards
- ◆ Front and rear edges are machined parallel to guide posts for ease in die building
- ◆ Shanks available upon request

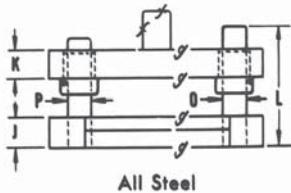
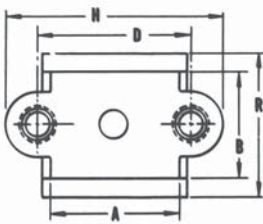

### CLAMP ASSEMBLY FOR DEMOUNTABLE BUSHINGS

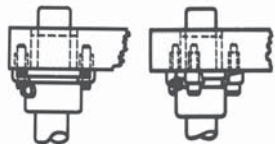

## WHEN ORDERING

1. Specify quantity and catalog number.
2. Specify type of **Danly** bushing. Unless otherwise specified, these sets are assembled with demountable steel shoulder bushings.
3. Specify length "L" from bottom of the die holder to top of guide post "O".
4. Specify diameter of punch shank. Punch shanks are integral and are available in the following sizes:

- ◆ 1-1/2" diameter x 2-1/8" long
- ◆ 1-9/16" diameter x 2-1/8" long
- ◆ 2" diameter x 2-7/8" long

Sets are also available without shanks. Special shanks can be furnished at additional cost.

5. Specify thickness combinations if other than listed. Other thicknesses are furnished at additional cost.
6. Specify how shipment should be made.

Catalog Numbers	Die Space		Thickness		General Dimensions				
	Left to Right	Front to Back	Die Holder	Punch Holder	For bushing and guide post specifications, see our <i>Die-makers' Supplies</i> catalog.				
All Steel	A	B	J	K	D	H	O	P	R
0304-CC1	3	4-1/8	1	1	4-1/2	7	3/4	7/8	4-1/8
0404-CC1	4-3/4	4-1/2	1-3/8	1-1/4	6-1/4	9	7/8	1	6-3/8
0604-CC1	6	4-3/4	1-1/2	1-1/2	7-1/4	10-5/8	1	1-1/4	6-5/8
0607-CC1	6	7-1/2			7-1/4	10-5/8			9-3/8
0705-CC1	7	5-1/2			8-1/4	11-1/2			7-3/8
0806-CC1	8-1/2	6			9-3/4	13			8
0808-CC1	8-1/2	8	9-3/4	13	10				
1010-CC1	10-1/2	10-1/2	12	15-5/8	1-1/4	1-1/2	12-1/4		

**NOTE:** All dimensions are in inches, unless otherwise noted.

# CATALOG DIE SETS

## The Danly IEM Value Proposition

- I. **Danly IEM** is recognized as the leader in manufacturing quality die sets and related products to the global parts forming industry. Our reputation has been built by satisfying customer needs, and we are very strong in the automotive and appliance industries.
- II. **Danly IEM** offers outstanding delivery on a consistent basis. Choosing us as a supplier means that our customers have a competitive advantage in delivering their products to the market.
- III. **Danly IEM** has complex machining capabilities on die sets at several strategically located facilities. Locations throughout the USA means lower shipping costs and allowing **Danly IEM** to machine complex die sets means the customer's machining centers have additional capacity.
- IV. **Danly IEM's** vast breadth of products assures innovative solutions. We strive to address customer problems by utilizing our research and development department as well as other technical professionals.
- V. **Danly IEM** has a technically trained sales force and distributor channels with engineering support. Sales, marketing and engineering professionals are available to support our product lines.

- **Competitive Prices**
- **Reliability and Performance**

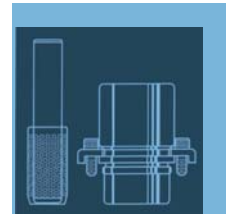
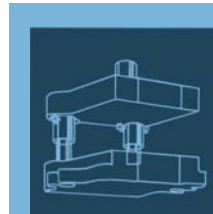

**...A LEADING MANUFACTURER  
AND INNOVATOR OF DIE SETS  
AND DIE COMPONENTS SUPPLIED  
GLOBALLY TO THE METAL  
FORMING INDUSTRY...**

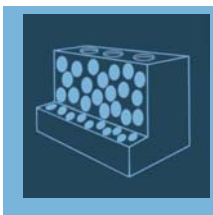

- **High Quality Design & Construction**
- **Outstanding Service & Support**



## CATALOG DIE SETS



Distributed by:

[www.danly.com](http://www.danly.com)  
[quotes@danly.com](mailto:quotes@danly.com)

**WITHIN THE USA & CANADA**

**CALL: 800-243-2659**

**FAX: 800-833-2659**

**OUTSIDE THE USA & CANADA**

**CALL: 001-248-489-7816**

**FAX: 001-248-553-6842**



**The Anchor Danly Company**