

# DAPCO®

Nitrogen Gas Springs

UT Series



- Up to 95 kN of force on contact
- UltraPak® cartridge for long life
- Operates self-contained or linked



The global leader in nitrogen gas spring technology

DADCO produces top quality products at competitive prices and provides a superior level of customer service. Founded in 1958, DADCO is the highest volume producer of gas springs for press tools. DADCO's products are widely approved and used in global operations for many industries including metal stamping, automotive and plastic injection molding.



### UT Series

This series consists of five models and provides force up to 95 kN on contact. Each model comes standard with a G 1/8 charging port for consistent link capability using the Zip (CNOMO) Fittings and 90.700 hose. Optionally, the UT.1000 and UT.2600 models are available with a pressure indicator installed for quick monitoring at a glance during operation.

Model	Diameter	Maximum Force on Contact
UT.1000	50 mm	9.24 kN
UT.2600	75 mm	23.86 kN
UT.4600	95 mm	42.41 kN
UT.6600	120 mm	66.27 kN
UT.9600	150 mm	95.43 kN

### High Quality Construction

To ensure their exceptionally long service life, DADCO's UT Series Gas Springs have high quality construction features. UT gas spring models are built with a one-piece piston rod and utilize a double lip rod seal for excellent load capacity and resistance to wear.

### Adjustable Force

For convenience, self-contained cylinders usually are delivered pre-charged to the desired force and ready to install. If force adjustment is ever needed, a filling/draining port is located in the cylinder for safe, easy access.

### UltraPak® Technology

The UT Series incorporates superior gas spring technology into DADCO's **UltraPak®** cartridge. The **UltraPak®** employs advanced materials to reduce the rod cartridge profile while increasing performance. The **UltraPak®** is comprised of a rod wiper, rod seal and guide arranged to extend life, retain lubrication, exclude contaminants, and provide excellent wear characteristics. When coupled with DADCO's superior finished piston rod, the **UltraPak®** is the ultimate sealing system in compact height gas springs.

### Numerous Piping Options

Many customers have recognized the benefits of piping gas springs to monitor, control, and adjust force from outside the die. DADCO offers a wide selection of hoses, fittings, control panels and equipment to simplify the piping process. For additional information request the Nitrogen Gas Spring Linked Components Catalog #C09118.

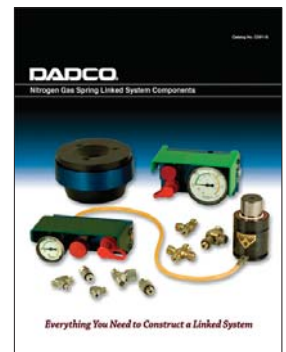

### Customer Satisfaction

DADCO's motto is "Whatever It Takes To Satisfy Our Customers." DADCO will assist in any way possible to ensure that customers are completely satisfied. DADCO's salespeople and distributors are solution-oriented, product-knowledgeable, and eager to assist customers. DADCO's engineers are available to help customers with specific applications.

### Rapid Delivery

DADCO's modern 11,600 m<sup>2</sup> main production facility as well as satellite facilities permit the fastest deliveries in the industry. Products are available both directly and through a network of trained distributors providing worldwide support.

### Warranty

DADCO warrants its UT Series Nitrogen Gas Springs to be free from defects in workmanship or materials for a period of one year from date of manufacture.

### CAD Templates On-line



DADCO's entire product line is available on-line in solid models and 2D CAD formats. For more information, visit our website, [www.dadco.net](http://www.dadco.net), or contact DADCO.

## Installation Examples

DADCO offers a variety of mount options to meet specific customer applications. Installation and fastening of the gas springs should take into consideration load support, fastener selection and torque values. For additional information on installation requirements see page 16. Cylinder and mount dimensions are shown on pages 4-13.

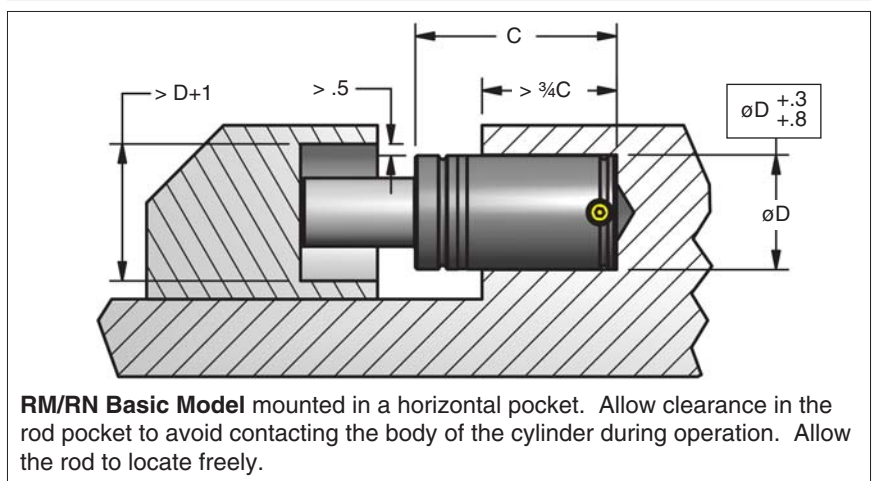
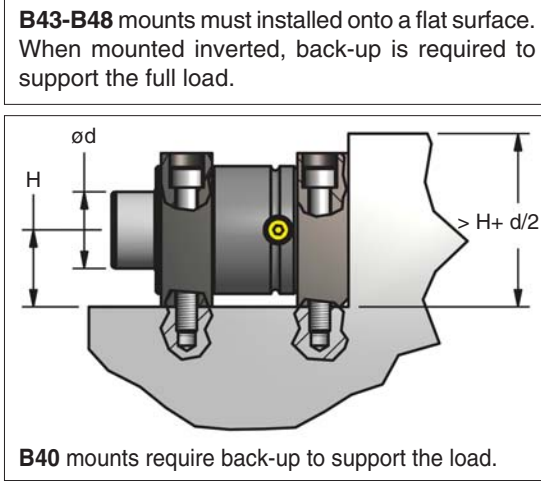
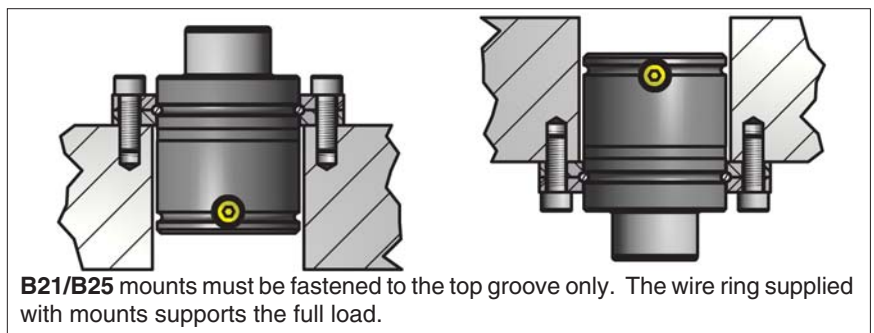
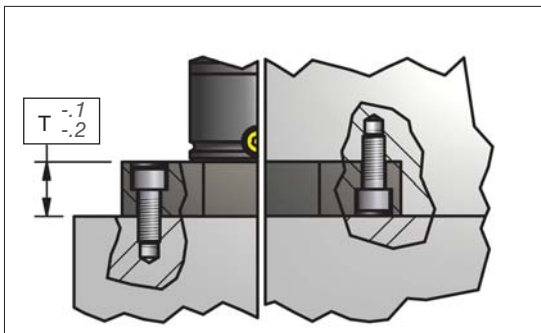
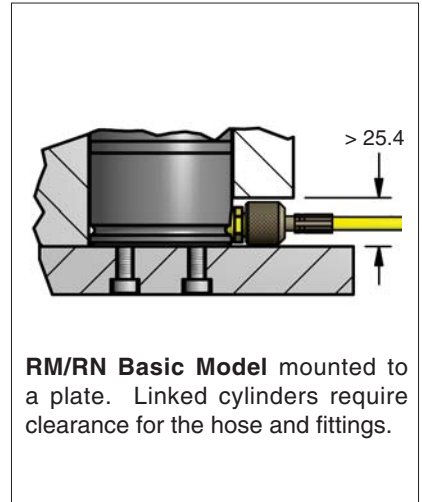
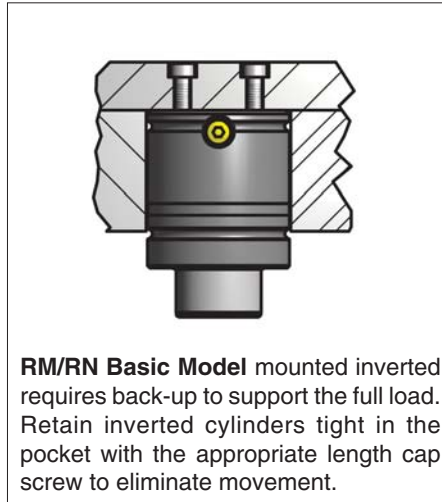
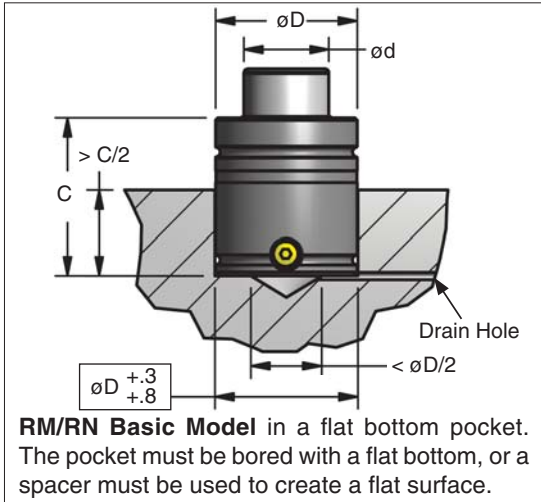

DADCO offers customized Sectional Mounting Systems, which are fabricated to customer specifications, leak tested and shipped ready to install. The drawing below shows six UT.2600 gas springs linked using DADCO's MINIFLEX® Y-700 hose, fittings and a Mini Control Panel.

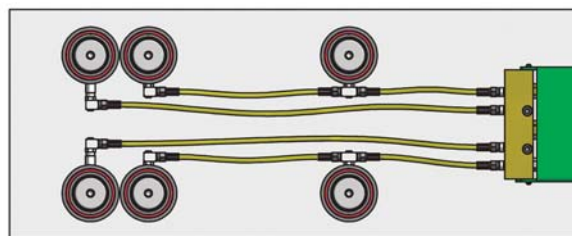

# UT Series Nitrogen Gas Springs

## UT.1000 - 9.2 kN / 1.0 ton

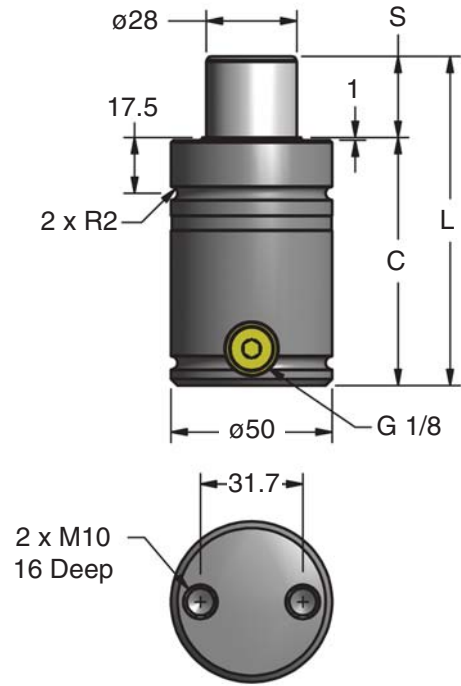

RM - Radius Groove

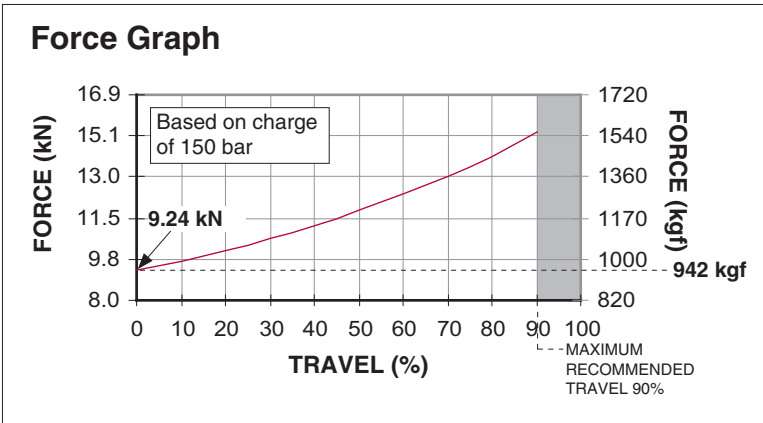

Part No.	S mm	On-Contact Force kN (kgf)	Max Force* kN (kgf)	C	L ±0.25	Pressure Increase* %	Weight kg
UT.1000.013	12.5	9.24 (942)	15.29 (1559)	64.5	77.0	65	0.79
UT.1000.016	16.0			68.0	84.0		0.82
UT.1000.019	19.0			71.0	90.0		0.85
• UT.1000.025	25.0			77.0	102.0		0.91
UT.1000.032	32.0			84.0	116.0		0.97
UT.1000.038	37.5			89.5	127.0		1.03
• UT.1000.050	50.0			102.0	152.0		1.14
UT.1000.063	62.5			114.5	177.0		1.26
• UT.1000.075	75.0			127.0	202.0		1.38
UT.1000.080	80.0			132.0	212.0		1.42
• UT.1000.100	100.0			152.0	252.0		1.61
• UT.1000.125	125.0			177.0	302.0		1.84

bar	MPa	kN	kgf
150	15.0	9.24	942
125	12.5	7.70	785
100	10.0	6.16	628
75	7.5	4.62	471
50	5.0	3.08	314
25	2.5	1.54	157
20	2.0	1.23	126

• Preferred Sizes

\*Based on maximum recommended travel, 90% stroke

## UT.1000 - 9.2 kN / 1.0 ton

### Mount Options

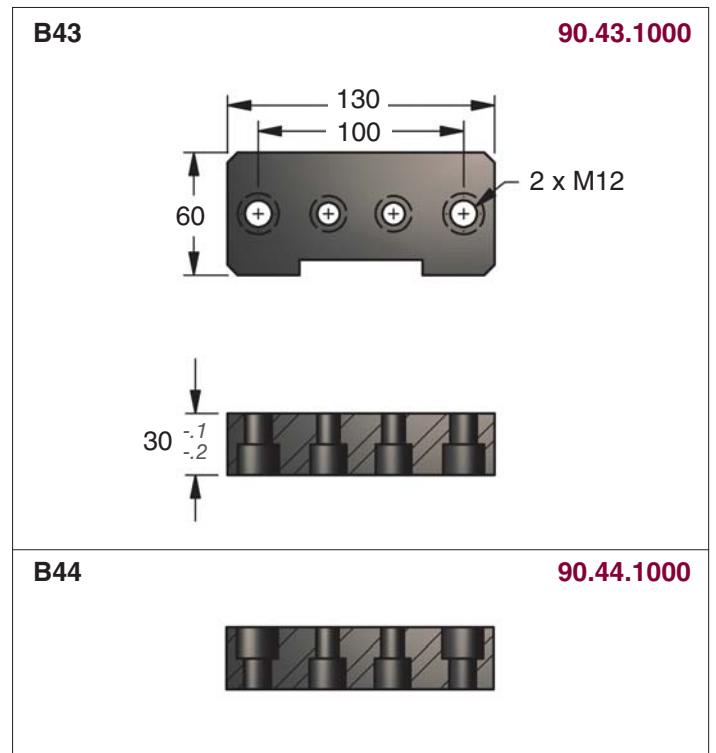
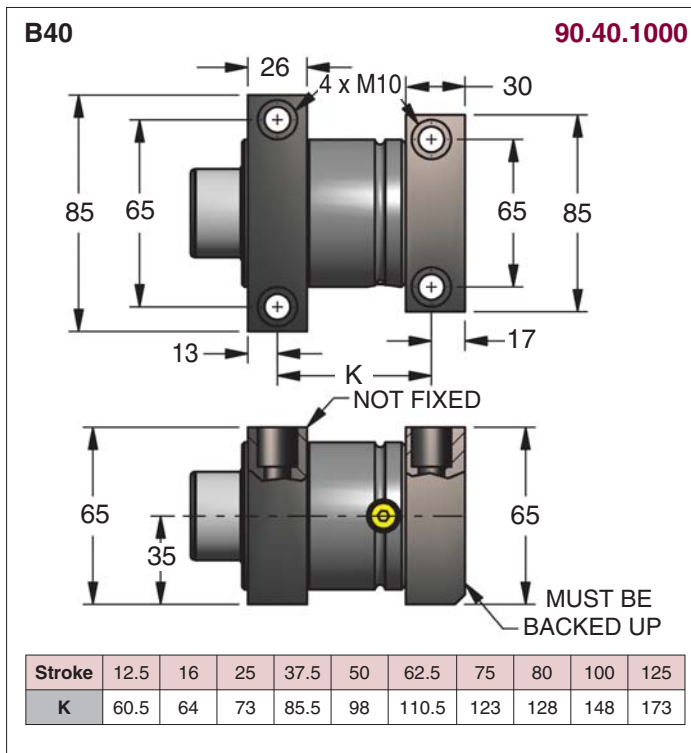
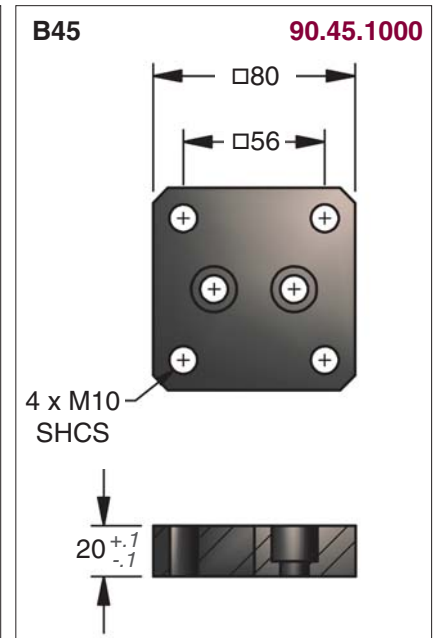
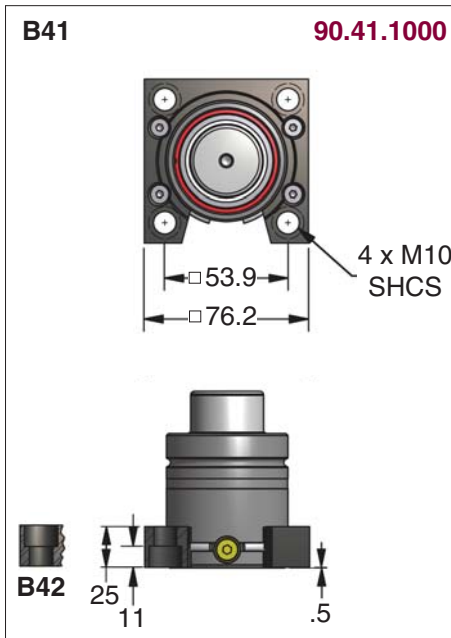
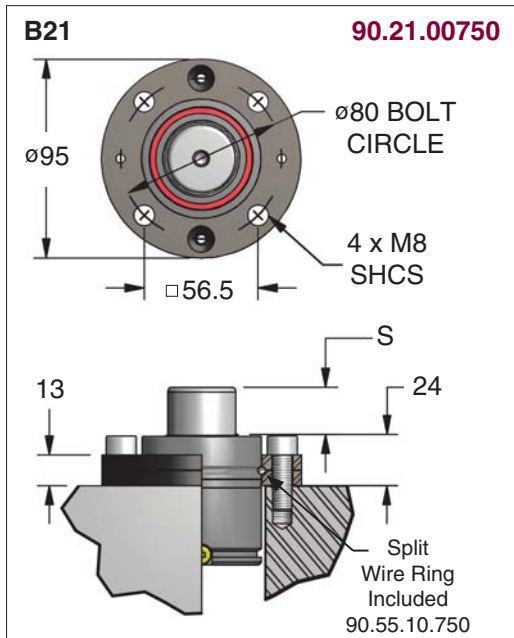

### Ordering Example:

<b>Model</b> UT.1000	<b>Stroke</b> 025	<b>Mount</b> B21	<b>Operating System</b> C	<b>Charging Pressure (bar)</b> 150
-------------------------	----------------------	---------------------	------------------------------	---------------------------------------

Part Number

RM: Radius Groove

C: Self-contained  
FB: Open Flow Fitting (90.805.115)  
CI\_: Self-contained with Indicator; refer to page 15.

15~150 bar (1.5~15 MPa)  
When not specified, default is 150 bar (15 MPa).

# UT Series Nitrogen Gas Springs

## UT.2600 - 24 kN / 2.6 ton

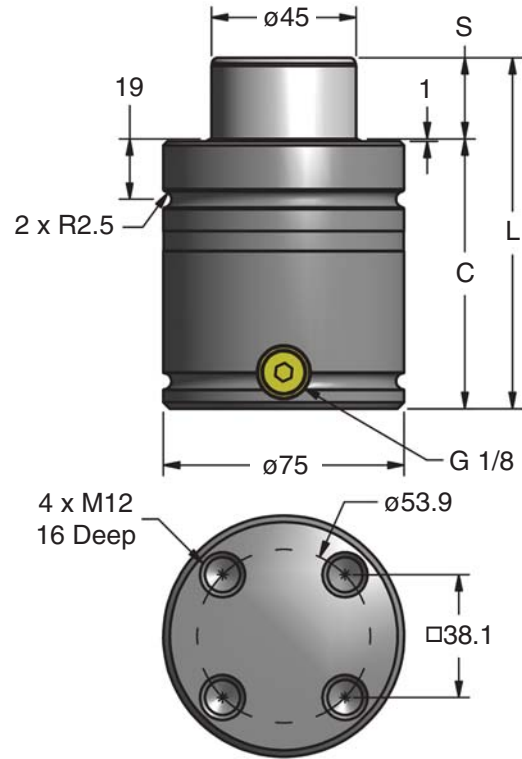

RN - Radius Groove

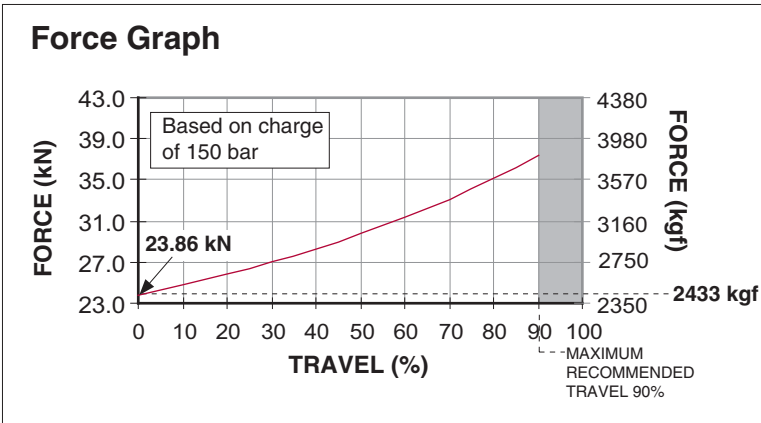

Part No.	S mm	On-Contact Force kN (kgf)	Max Force* kN (kgf)	C	L ±0.25	Pressure Increase* %	Weight kg
UT.2600.016	16.0	23.86 (2433)	37.52 (3826)	75.0	91.0	57	2.01
UT.2600.019	19.0			78.0	97.0		2.06
• UT.2600.025	25.0			84.0	109.0		2.16
UT.2600.032	32.0			91.0	123.0		2.28
UT.2600.038	37.5			96.5	134.0		2.37
• UT.2600.050	50.0			109.0	159.0		2.58
UT.2600.063	62.5			121.5	184.0		2.79
• UT.2600.075	75.0			134.0	209.0		3.01
UT.2600.080	80.0			139.0	219.0		3.09
• UT.2600.100	100.0			159.0	259.0		3.43
• UT.2600.125	125.0			184.0	309.0		3.85

On-Contact Force			
bar	MPa	kN	kgf
150	15.0	23.86	2433
125	12.5	19.88	2027
100	10.0	15.90	1622
75	7.5	11.93	1216
50	5.0	7.95	811
25	2.5	3.98	405
20	2.0	3.18	324

• Preferred Sizes

\*Based on maximum recommended travel, 90% stroke

# UT.2600 - 24 kN / 2.6 ton

## UT Series Nitrogen Gas Springs

### Mount Options

**B21** 90.21.01500

ø104 BOLT CIRCLE  
4 x M10 SHCS  
ø122  
□73.5  
16  
S  
27  
Split Wire Ring Included  
90.55.1500

**B325** 90.325.2600

4 x M10 SHCS  
□90  
□73.5  
16  
S  
29  
Split Wire Ring Included  
90.55.1500

**B41** 90.41.2600

4 x M12 SHCS  
□101.6  
□76.2  
25  
13  
.5

**B45** 90.45.2600

□120  
□90  
M16  
4 x M12  
30<sup>-0.1</sup><sub>-0.2</sub>

**B42** 90.46.2600

30<sup>-0.1</sup><sub>-0.2</sub>

**B40** 90.40.2600

30 4 x M12 30  
120 95 75 100  
15 K 17  
90 45  
NOT FIXED  
MUST BE BACKED UP

**B43** 90.43.2600

150 120 80 50  
4 x M12  
M16  
30<sup>-0.1</sup><sub>-0.2</sub>

**B47** 90.47.2600

210 90 90 120  
90 90  
6 x M12  
30<sup>-0.1</sup><sub>-0.2</sub>

**B44** 90.44.2600

30<sup>-0.1</sup><sub>-0.2</sub>

**B48** 90.48.2600

30<sup>-0.1</sup><sub>-0.2</sub>

Stroke	16	19	25	32	37.5	50	62.5	75	80	100	125
K	69	72	78	85	90.5	103	115.5	128	133	153	178

### Ordering Example:

Model	Stroke	Mount	Operating System	Charging Pressure (bar)
UT.2600	025	B21	C	150

Part Number

RN: Radius Groove

C: Self-contained  
FB: Open Flow Fitting (90.805.115)

Cl\_: Self-contained with Indicator; refer to page 15.

15~150 bar (1.5~15 MPa)  
When not specified, default is 150 bar (15 MPa).

734.207.1100 • 800.DADCO.USA • fax 734.207.2222 • www.dadco.net

**DADCO**

7

# UT Series Nitrogen Gas Springs

## UT.4600 - 42 kN / 4.3 ton

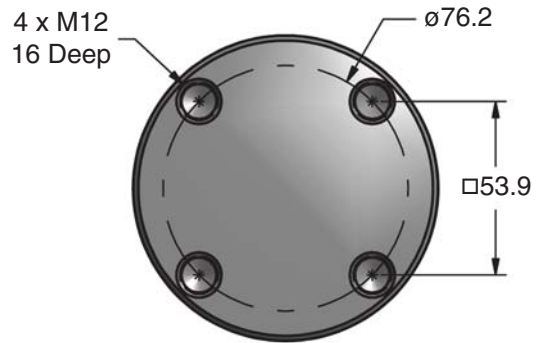
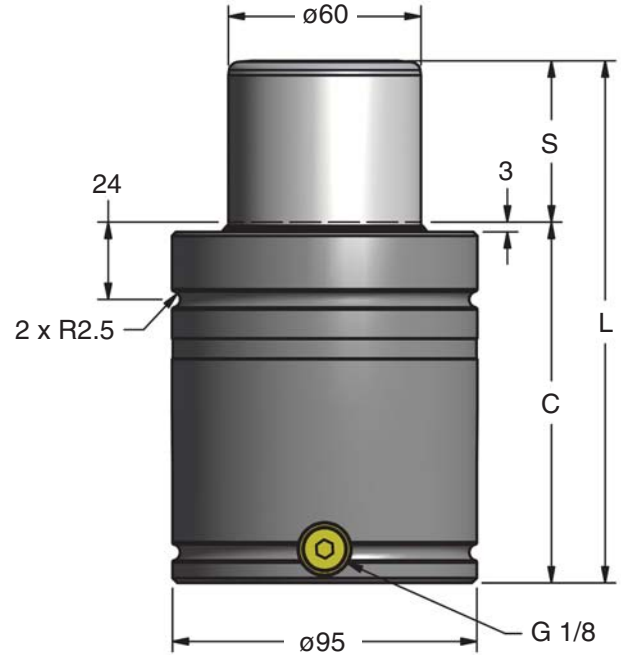

RM - Radius Groove

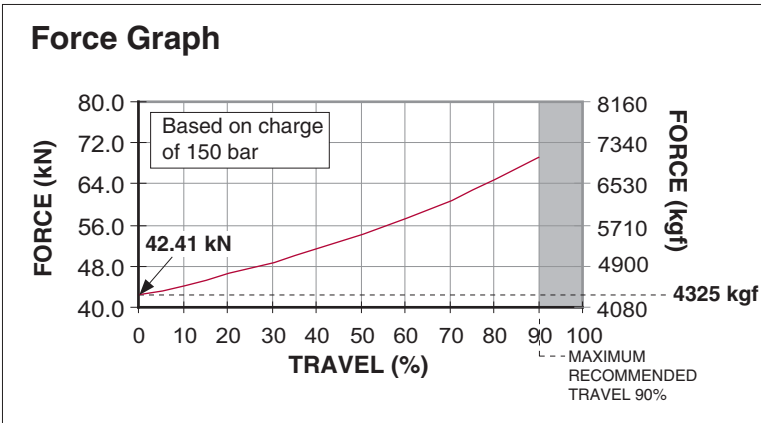

Part No.	S mm	On-Contact Force kN (kgf)	Max Force* kN (kgf)	C	L $\pm 0.25$	Pressure Increase* %	Weight kg
UT.4600.016	16.0	42.41 (4325)	69.34 (7070)	78.0	94.0	63	3.26
UT.4600.019	19.0			81.0	100.0		3.35
• UT.4600.025	25.0			87.0	112.0		3.52
UT.4600.032	32.0			94.0	126.0		3.73
UT.4600.038	37.5			99.5	137.0		3.89
• UT.4600.050	50.0			112.0	162.0		4.25
UT.4600.063	62.5			124.5	187.0		4.62
• UT.4600.075	75.0			137.0	212.0		4.98
UT.4600.080	80.0			142.0	222.0		5.13
• UT.4600.100	100.0			162.0	262.0		5.71
• UT.4600.125	125.0			187.0	312.0		6.44

### On-Contact Force

bar	MPa	kN	kgf
150	15.0	42.41	4325
125	12.5	35.34	3604
100	10.0	28.27	2883
75	7.5	21.21	2162
50	5.0	14.14	1442
25	2.5	7.07	721
20	2.0	5.65	577

• Preferred Sizes

\*Based on maximum recommended travel, 90% stroke

# UT.4600 - 42 kN / 4.3 ton

## UT Series Nitrogen Gas Springs

### Mount Options

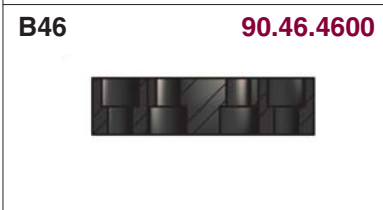
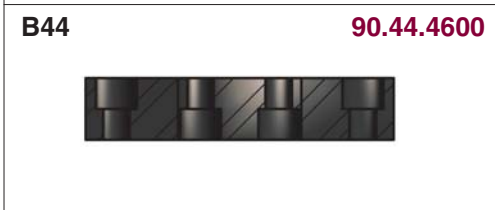
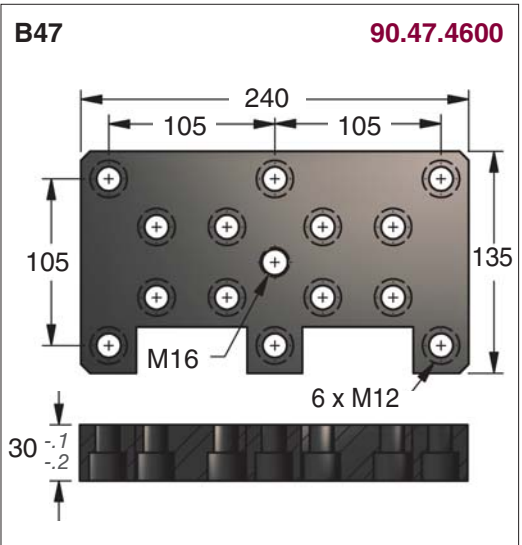
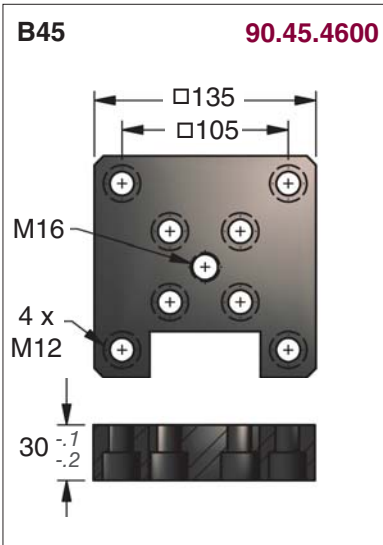
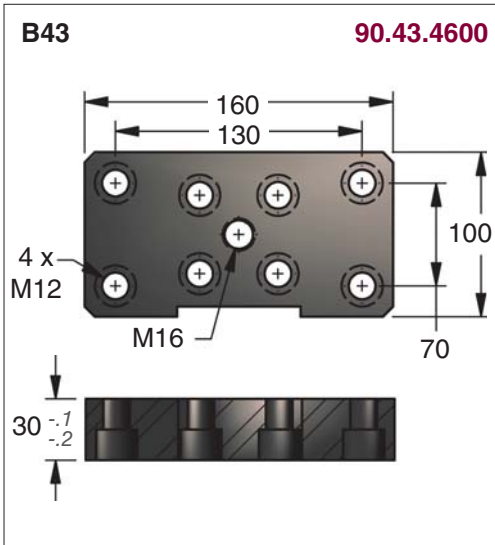
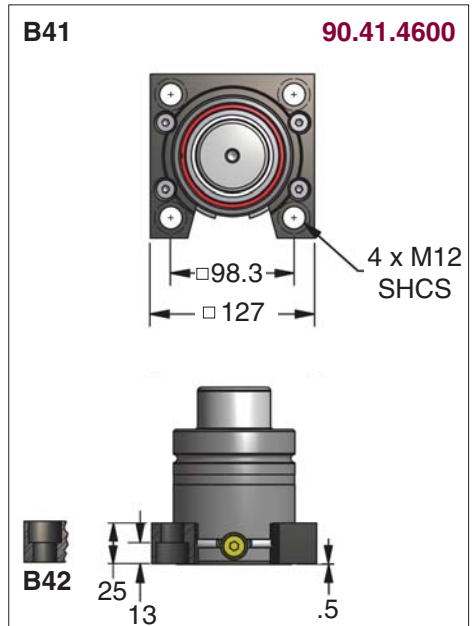
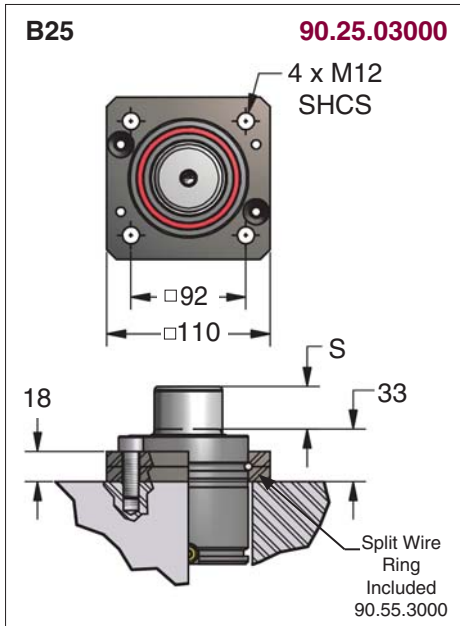
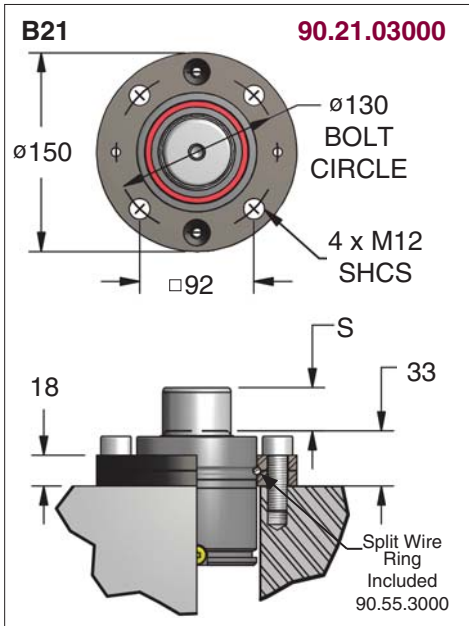

### Ordering Example:

<b>Model</b> UT.4600	<b>Stroke</b> 025	<b>Mount</b> B21	<b>Operating System</b> C	<b>Charging Pressure (bar)</b> 150
-------------------------	----------------------	---------------------	------------------------------	---------------------------------------

Part Number

RM: Radius Groove

C: Self-contained  
FB: Open Flow Fitting (90.805.115)

15~150 bar (1.5~15 MPa)  
When not specified, default is 150 bar (15 MPa).

# UT Series Nitrogen Gas Springs

## UT.6600 - 66 kN / 7.4 ton

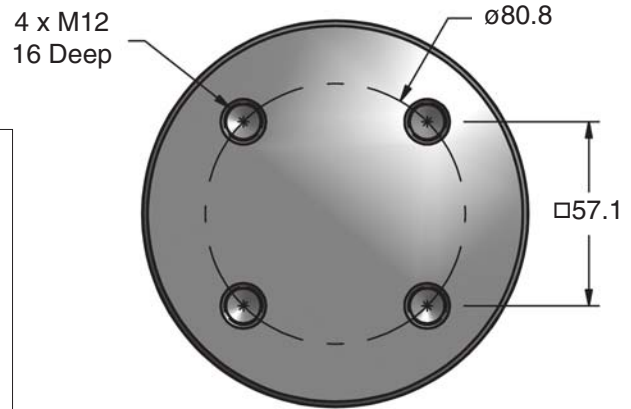
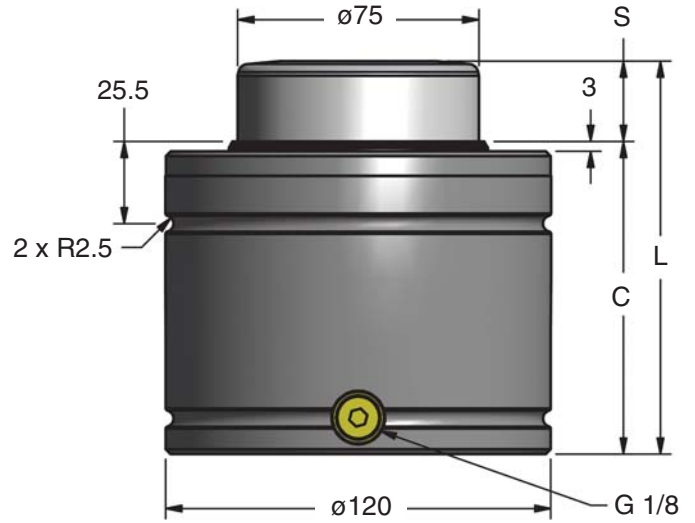

RM - Radius Groove

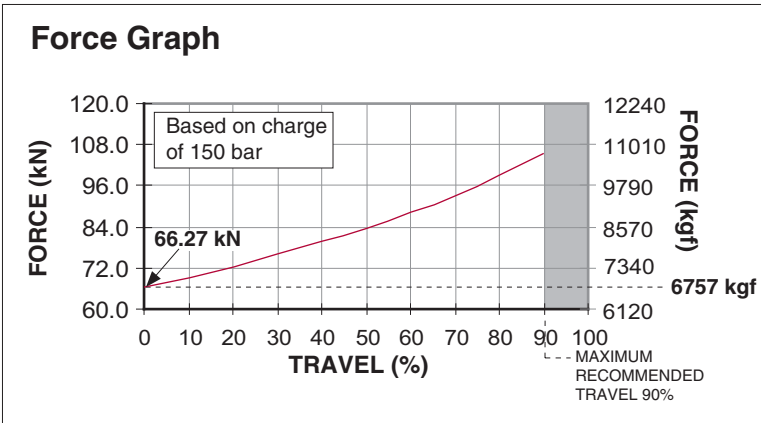

Part No.	S mm	On-Contact Force kN (kgf)	Max Force* kN (kgf)	C	L $\pm 0.25$	Pressure Increase* %	Weight kg
UT.6600.016	16.0	66.27 (6757)	104.14 (10619)	88.0	104.0	57	6.00
UT.6600.019	19.0			91.0	110.0		6.14
• UT.6600.025	25.0			97.0	122.0		6.41
UT.6600.032	32.0			104.0	136.0		6.73
UT.6600.038	37.5			109.5	147.0		6.98
• UT.6600.050	50.0			122.0	172.0		7.56
UT.6600.063	62.5			134.5	197.0		8.13
• UT.6600.075	75.0			147.0	222.0		8.70
UT.6600.080	80.0			152.0	232.0		8.93
• UT.6600.100	100.0			172.0	272.0		9.84
• UT.6600.125	125.0			197.0	322.0		10.99

bar	MPa	kN	kgf
150	15.0	66.27	6757
125	12.5	55.22	5631
100	10.0	44.18	4505
75	7.5	33.13	3379
50	5.0	22.09	2252
25	2.5	11.04	1126
20	2.0	8.84	901

• Preferred Sizes

\*Based on maximum recommended travel, 90% stroke

# UT.6600 - 66 kN / 7.4 ton

## UT Series Nitrogen Gas Springs

### Mount Options

<p><b>B21</b> <span style="color: red;">90.21.05000</span></p> <p>∅175 ∅155 BOLT CIRCLE 4 x M12 SHCS 109.5 S 21 36 Split Wire Ring Included 90.55.5000</p>	<p><b>B25</b> <span style="color: red;">90.25.05000</span></p> <p>4 x M12 SHCS 109.5 130 S 21 36 Split Wire Ring Included 90.55.5000</p>	<p><b>B41</b> <span style="color: red;">90.41.6600</span></p> <p>4 x M12 SHCS 14.3 139.7 S 25 13 5 Split Wire Ring Included 90.55.5000</p>
<p><b>B43</b> <span style="color: red;">90.43.6600</span></p> <p>200 160 130 4 x M16 M16 90 35 <sup>-0.1</sup>/<sub>-0.2</sub></p>	<p><b>B45</b> <span style="color: red;">90.45.6600</span></p> <p>170 130 M16 4 x M16 35 <sup>-0.1</sup>/<sub>-0.2</sub></p>	<p><b>B47</b> <span style="color: red;">90.47.6600</span></p> <p>300 130 130 170 M16 6 x M16 35 <sup>-0.1</sup>/<sub>-0.2</sub></p>
<p><b>B44</b> <span style="color: red;">90.44.6600</span></p> <p>35 <sup>-0.1</sup>/<sub>-0.2</sub></p>	<p><b>B46</b> <span style="color: red;">90.46.6600</span></p> <p>35 <sup>-0.1</sup>/<sub>-0.2</sub></p>	<p><b>B48</b> <span style="color: red;">90.48.6600</span></p> <p>35 <sup>-0.1</sup>/<sub>-0.2</sub></p>

### Ordering Example:

<b>Model</b> UT.6600	•	<b>Stroke</b> 025	•	<b>Mount</b> B21	•	<b>Operating System</b> C	•	<b>Charging Pressure (bar)</b> 150
-------------------------	---	----------------------	---	---------------------	---	------------------------------	---	---------------------------------------

Part Number

RM: Radius Groove

C: Self-contained  
FB: Open Flow Fitting (90.805.115)

15~150 bar (1.5~15 MPa)  
When not specified, default is 150 bar (15 MPa).

# UT Series Nitrogen Gas Springs

## UT.9600 - 95 kN / 10.7 ton

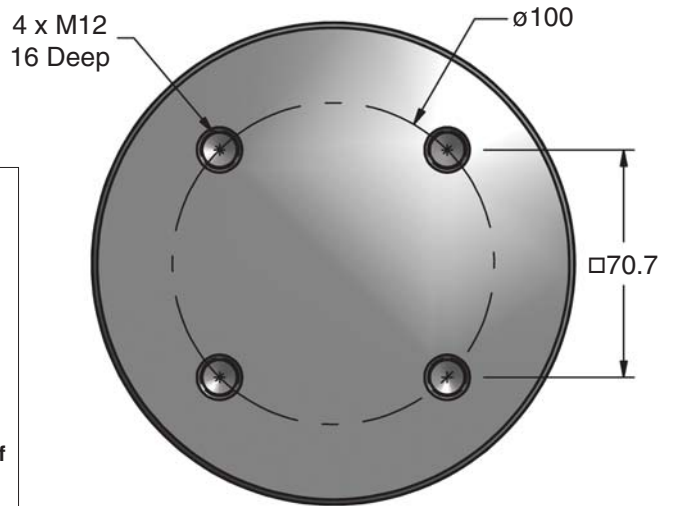
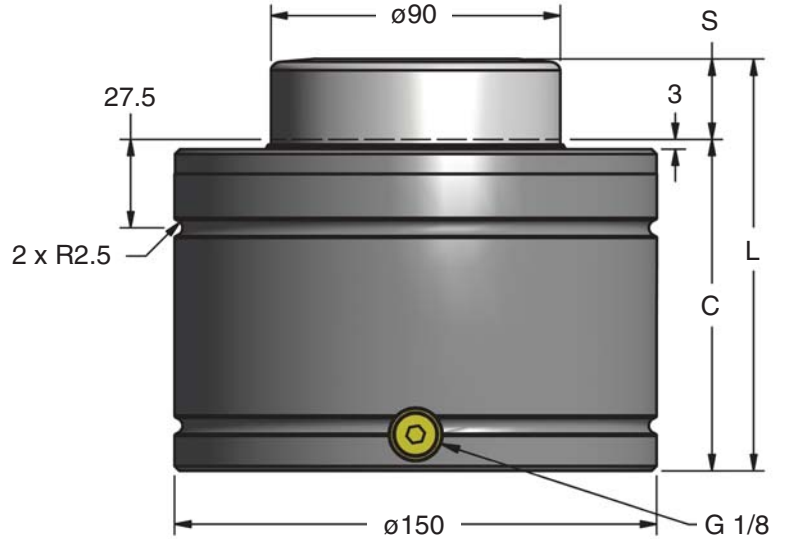

RM - Radius Groove

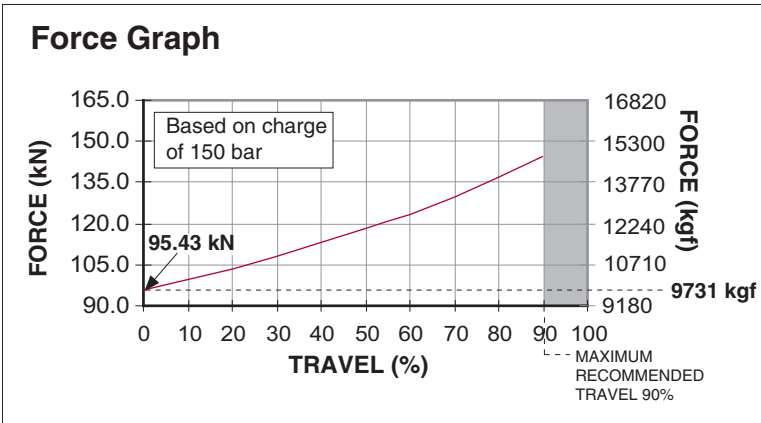

Part No.	S mm	On-Contact Force kN (kgf)	Max Force* kN (kgf)	C	L $\pm 0.25$	Pressure Increase* %	Weight kg
• UT.9600.025	25.0	95.43 (9731)	144.32 (14717)	103.0	128.0	51	10.68
UT.9600.032	32.0			110.0	142.0		11.17
UT.9600.038	37.5			115.5	153.0		11.55
• UT.9600.050	50.0			128.0	178.0		12.42
UT.9600.063	62.5			140.5	203.0		13.29
• UT.9600.075	75.0			153.0	228.0		14.16
UT.9600.080	80.0			158.0	238.0		14.51
• UT.9600.100	100.0			178.0	278.0		15.90
• UT.9600.125	125.0			203.0	328.0		17.64

bar	MPa	kN	kgf
150	15.0	95.43	9731
125	12.5	79.52	8109
100	10.0	63.62	6487
75	7.5	47.71	4865
50	5.0	31.81	3244
25	2.5	15.90	1622
20	2.0	12.72	1297

• Preferred Sizes

\*Based on maximum recommended travel, 90% stroke

**UT.9600 - 95 kN / 10.7 ton**

**Mount Options**

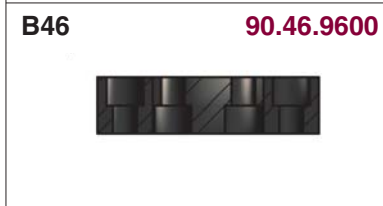
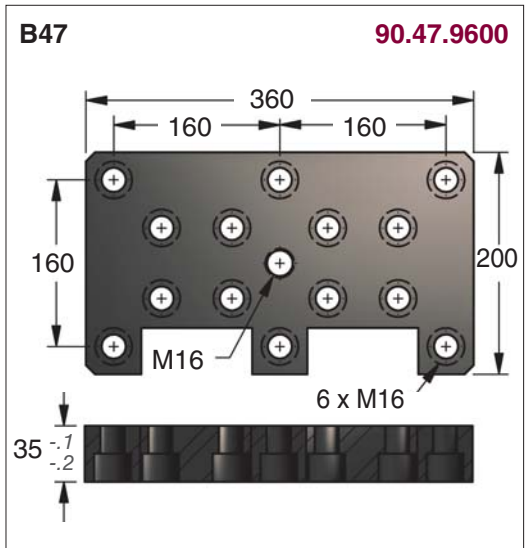
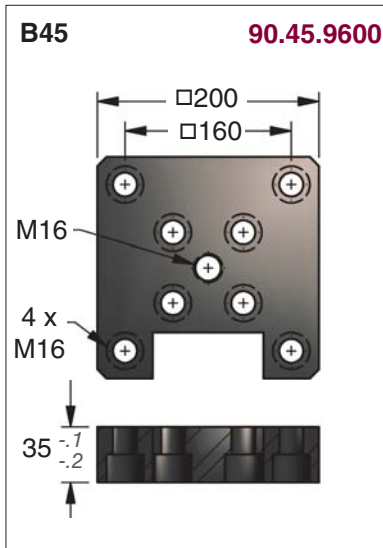
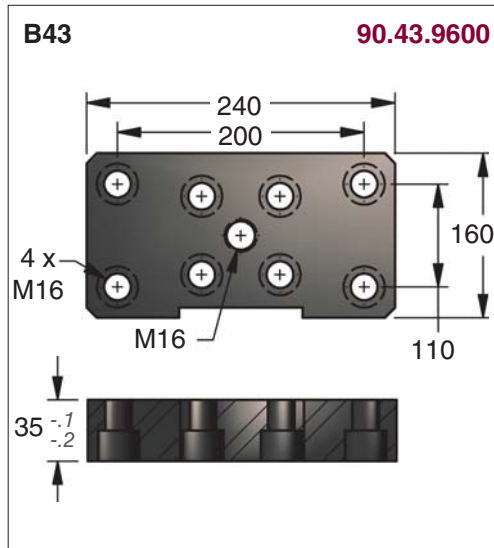
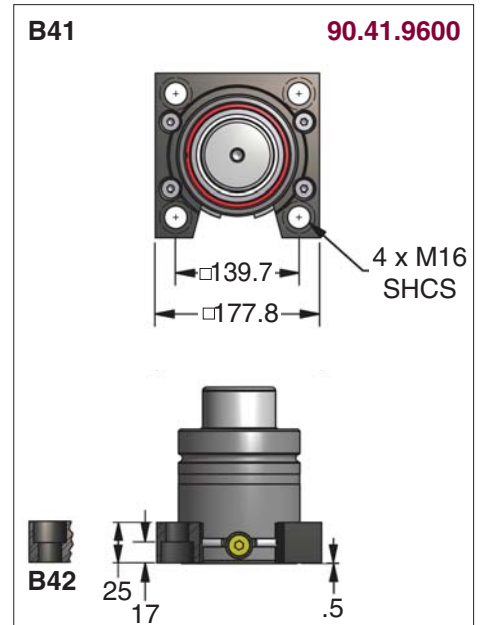
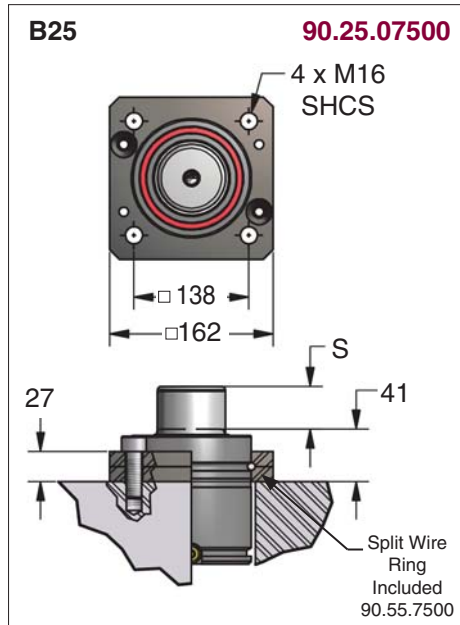
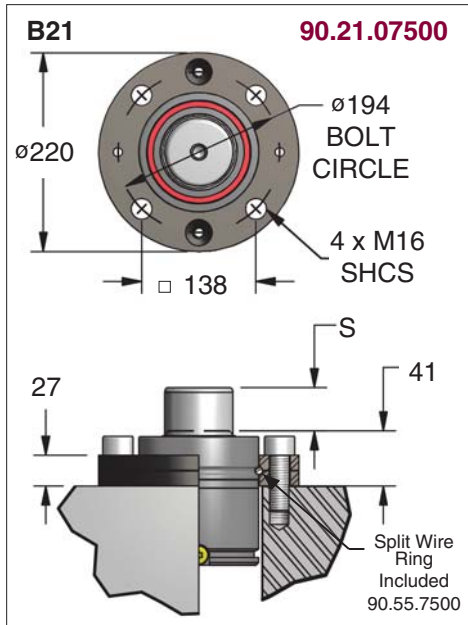

**Ordering Example:**

<b>Model</b> UT.9600	•	<b>Stroke</b> 025	•	<b>Mount</b> B21	•	<b>Operating System</b> C	•	<b>Charging Pressure (bar)</b> 150
-------------------------	---	----------------------	---	---------------------	---	------------------------------	---	---------------------------------------

Part Number

RM: Radius Groove

C: Self-contained  
FB: Open Flow Fitting (90.805.115)

15~150 bar (1.5~15 MPa)  
When not specified, default is 150 bar (15 MPa).

Request Catalog #C09118 for a comprehensive list of components necessary to configure a linked system.

### Hose and Hose Assemblies

**MINIFLEX® 90.700 (Y-700) Hose**  
 90.700.\_\_\_\_\_  
 Length (mm)

DADCO's MINIFLEX® hose is used to connect gas springs together as a linked system. MINIFLEX® hose is able to withstand high pressure and still maintain the flexibility necessary when linking gas springs.

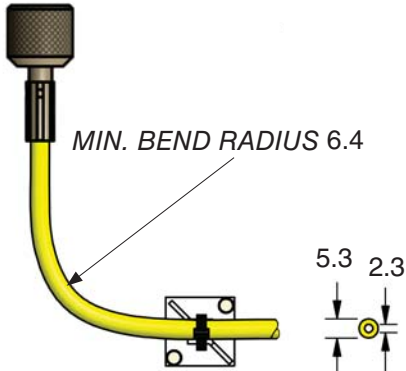

Working Pressure	Burst Pressure
413 bar (41 MPa)	1655 bar (165 MPa)

**Hose Assembly with two 90.804.943 (B-943) Hose Adapters**  
 90.700.B943.B943.\_\_\_\_.L  
 L

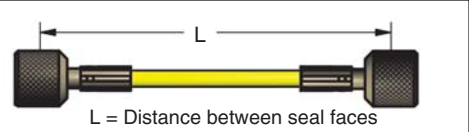

**Hose Assembly with one 90.804.943 (B-943) Hose Adapter and one 90.804.959 (B-959) Hose Adapter**  
 90.700.B943.B959.\_\_\_\_.L  
 L

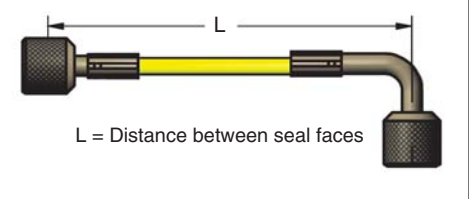

**Hose Assembly with two 90.804.959 (B-959) Hose Adapters**  
 90.700.B959.B959.\_\_\_\_.C  
 L

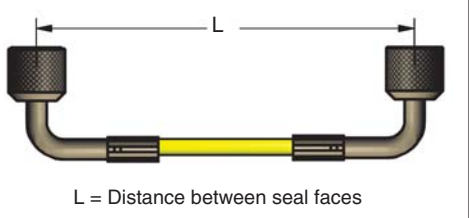

**Hose Assembly with two 90.804.959 (B-959) Hose Adapters**  
 90.700.B959.B959.\_\_\_\_.S  
 L

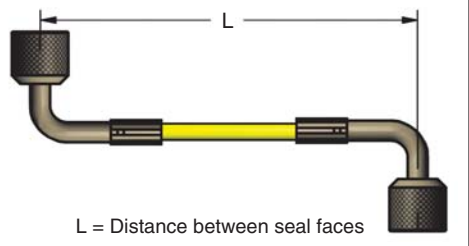

### Hose and Port Adapters: Zip (CNOMO)

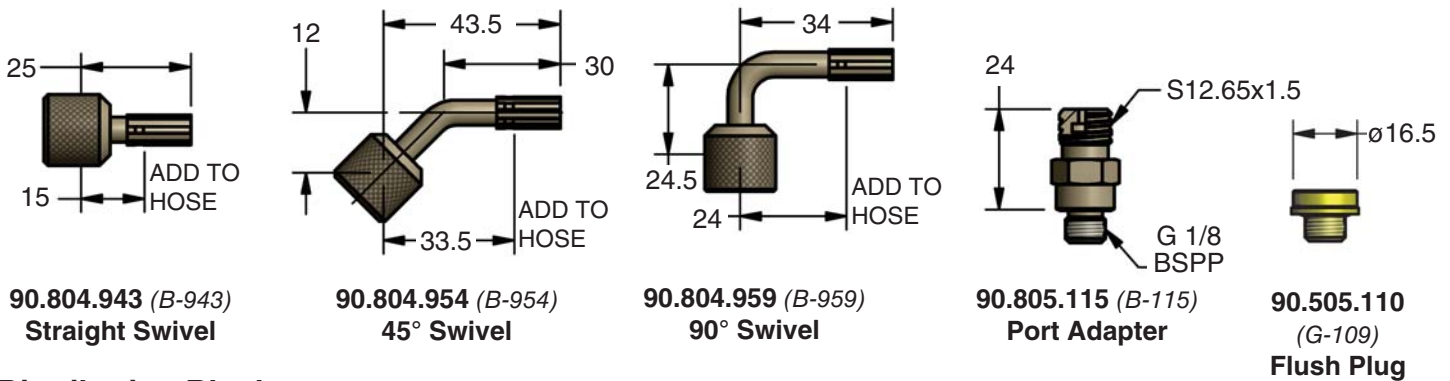

### Distribution Block

90.412.07 / 90.412.09 / 90.412.10 / 90.412.12

The distribution block is used with a control panel to simplify piping to multiple cylinders.

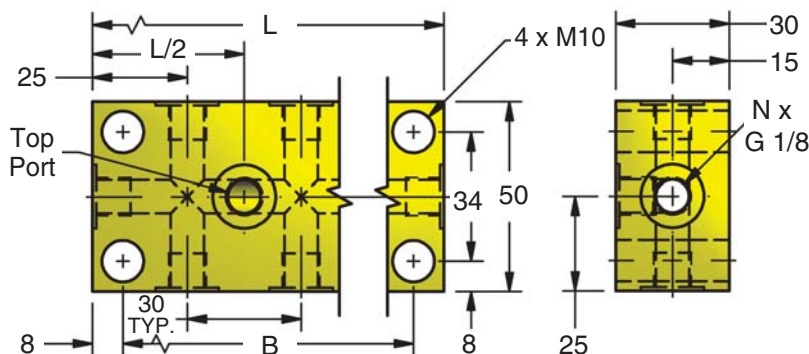

Model	N (Total Ports)	End Ports	Top Port	Side Ports	L	B
90.412.07	7	2	1	4	80	64
90.412.09	9	2	1	6	110	94
90.412.10	10	2	-	8	140	124
90.412.12	12	2	-	10	170	154

## Linked Operations

### Common Control Panel

#### 90.416.A2B

The DADCO Common Control Panel is used to fill, drain, and monitor the pressure of linked DADCO Nitrogen Gas Springs from outside the die. The panel consists of a high pressure gauge (MPa and bar), quick disconnect fill valve, and a rupture disk to prevent overpressurization.

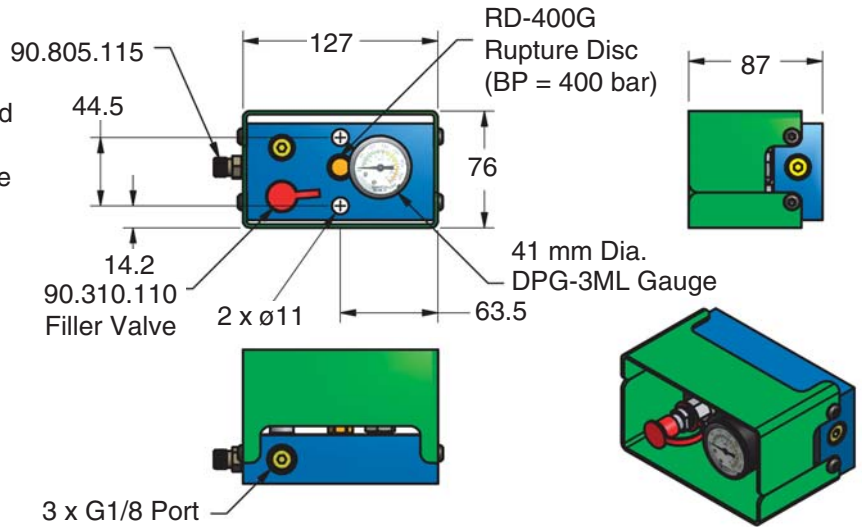

### Control Panel with Pressure Monitor

#### 90.406.421

The DADCO Control Panel with Pressure Monitor is used to maintain the pressure of linked DADCO Nitrogen Gas Springs from outside the die. This panel includes a digital pressure sensor with programmable output to signal the press to stop running if pressure drops below a preset level. The control panel is outfitted with a high pressure gauge (MPa and bar), quick disconnect fill valve, and a rupture disk to prevent over pressurization. Contact DADCO for more information.

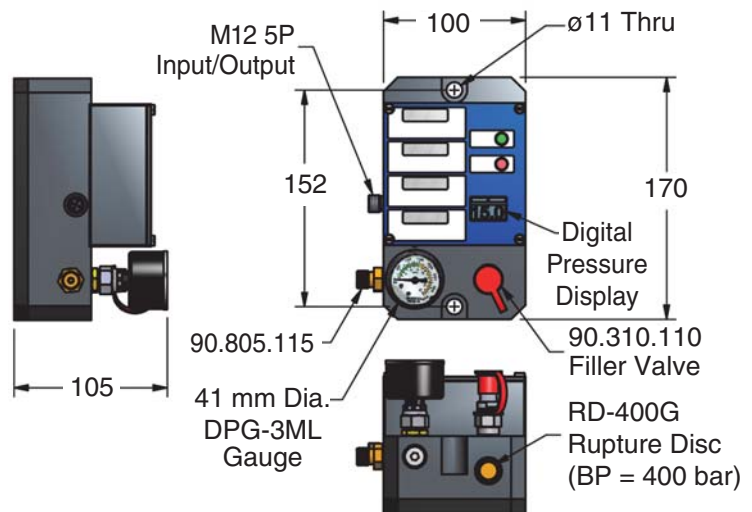

### Pressure Indicator

DADCO offers an optional pressure indicator for the UT.1000 and UT.2600 models. This indicator is preset and installed in a special G 1/8 port and designates that the gas spring pressure is above the preset value. The charging pressure must be a minimum of 20 bar/2 MPa above the preset value when the indicator is installed; refer to ordering example. The pressure indicator requires manual reset upon recharging. Contact DADCO for more information.

#### Operation Example:

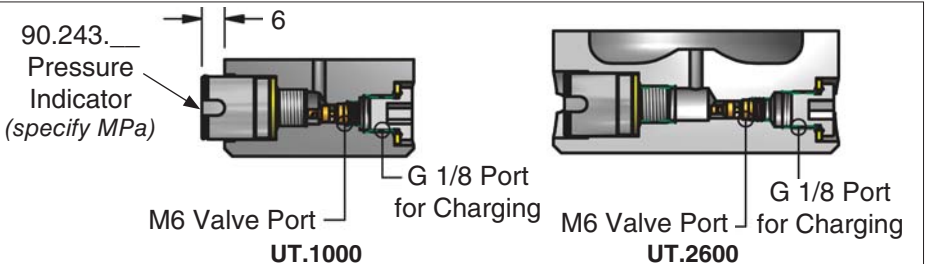
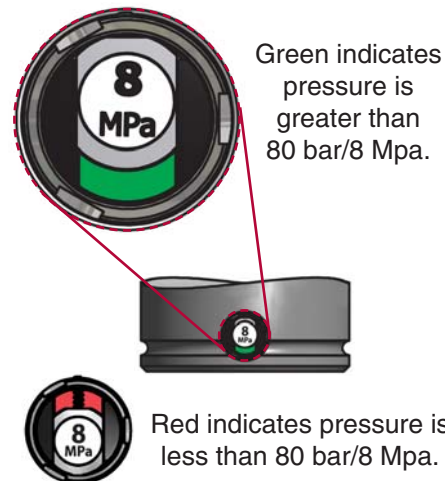

#### Ordering Example:

Model	Stroke	Mount	Operating System	Charging Pressure (bar)
UT.1000	025	RM	CI	100
UT.1000	025	RM	CI08	100

Part Number  
UT.1000 or UT.2600

Self-contained with pressure indicator (specify MPa).  
CI08 = 8 Mpa

Must be charged at a minimum of 20 bar/2 Mpa above preset pressure indicator value.

### CAUTION

DO NOT attempt maintenance on spring until internal pressure is exhausted.

### Operating Specifications

Charging Medium:	Nitrogen Gas	Operating Temperature:	-6°C – 71°C
Charging Pressure:	15 – 150 bar (1.5 – 15 MPa)	Maximum Speed:	1 m/sec

### Provide Stroke Reserve

- DADCO UT Series gas springs will permit travel of the full nominal stroke; however, at least a 10% stroke reserve is recommended to achieve optimal performance and safety (F.1 and F.2).

### Avoid Side Loading

- A misaligned press or die can cause side loading that increases wear on the bearing, seal, and piston rod (F.4). Therefore, avoid side loading when possible (F.3).

### Rod End Thread

- The end of the piston rod has a construction thread intended for assembly and disassembly purposes only, and should never be used to mount or secure the gas spring (F.4). Die vibration and/or misalignment will damage the spring.

### Protect From Fluids

- Direct contact with certain die lubricants and cleaners should be avoided (F.6). Protect gas springs by providing adequate drainage in gas spring pockets (F.5).

### Discharging Self-Contained Gas Spring

- The DADCO Pressure Analyzer (90.315.5) allows for charging, discharging and gauging of the pressure in the gas springs (F.7).

### Recharging Self-Contained Gas Spring

- Hold the spring vertically at all times during filling. Never compress the gas spring in a vice or clamp outside of the die or application as damage to the gas spring can result (F.8).
- Never fill a gas spring unless the rod is in the fully extended position (F.10). Thread the T-handle (90.320.2), into the rod end and depress the valve stem with the Valve Bleed Tool (90.360.4) or Port Servicing Tool (90.320.8). Pull the rod cartridge assembly up until it is seated firmly against the retaining ring (F.9). Remove the T-handle from the rod and charge the gas spring to the desired pressure. Refer to the Maintenance Instructions for complete step-by-step instruction.

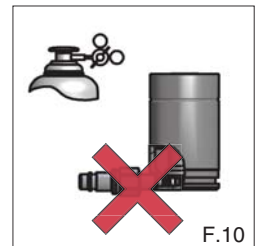
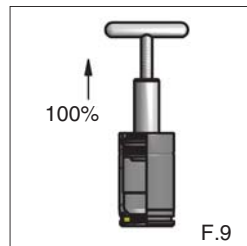
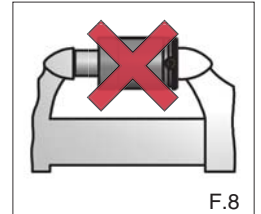
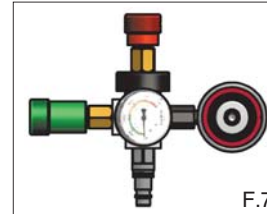
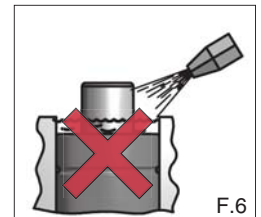
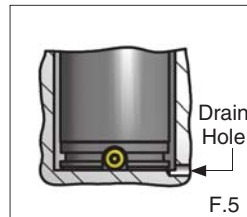
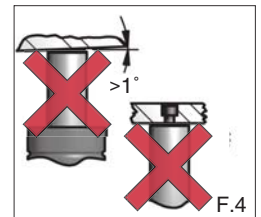
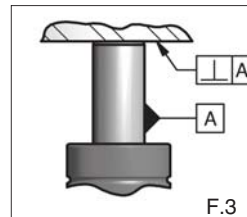
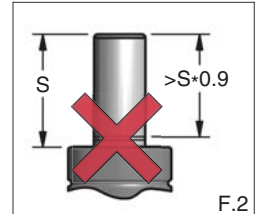
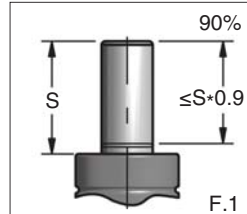

### Converting from Self-Contained mode to Linked mode

#### Remove Port Plug (A.1).

#### Exhausting the Spring

- With the cylinder in the horizontal position, exhaust the gas spring by depressing the valve stem using the appropriate tool (A.2). Keep face and hands clear of the port.
- After all the gas pressure is exhausted, be sure that the piston rod will retract into the tube manually. If not, try depressing the valve stem again. If still unsuccessful **STOP** and contact your DADCO Service Representative.

#### Remove Valve

- Remove the valve by unscrewing it using the appropriate tool (A.3).

#### Ready to Pipe

- Install a port adapter into the open G 1/8 port, (A.4). A wide variety of port adapters and fittings are available, contact DADCO for more information.

